

# PROXXON

## *Tools with Character!*



**PROXXON**  
**INDUSTRIAL**



**Socket sets by PROXXON. Manufactured according to the most modern production methods in the world's largest cold forge for tools.**

**PROXXON**  
**INDUSTRIAL**

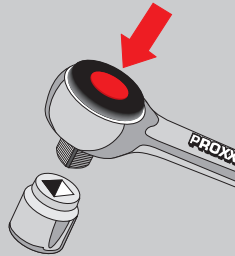

**The ratchet – the key item :**

Made from CrV steel in one single piece. Hardened and with perfect toothing: several of the 52 teeth engage simultaneously for transmitting extremely high torque. Quick release mechanism: releasing sockets at the push of the button. Optimum surface protection: twice nickel plated then chromed in matt finish. Non-detachable handle made from oil and acid-resistant TPR (thermoplastic rubber) with practical hole for hanging up.

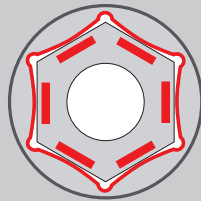

**The PROXXON driver system:**

The driving force is applied to the flanks, not the corners. This ensures high power transmission without damaging the corners of the nut or bolt.

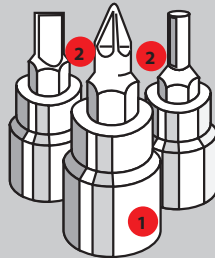

**Screwdriver bits:**

With CrV socket ①. The drive bits are all an optimum combination of chrome-silicon-manganese-molybdenum steel ②.

**All bits and accessories are forged using 31CrV steel.**

High carbon content to ensure consistent hardness. ③ Deep, uniform forging is fully guaranteed on the hex. drive side ④ to ensure that protruding studs do not present a problem. Thin-wall construction ⑤ for better access while maintaining strength for heavy work. Lead-in chamfer allows socket to slide over nuts easily. Machined fits on drive square ⑥ allow ratchet to arrest properly. Beginning with the 19mm size the outer diameter ⑦ of the sockets is reduced on the drive square end for improved handling ⑧. Optimum surface protection: Double nickel-plating and single matt-finished chrome-plating.

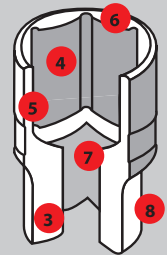

**DIN**  
**ISO**

**Quality at its best:**

Highest quality, exceeds DIN/ISO requirements for hardness and maximum torque. Individual size tolerances are all well within the prescribed norms.

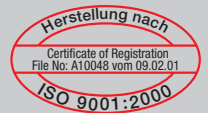

Socket sizes easy to read due to laser marking!

**Forged of chromium-vanadium steel 31 CrV3. In sturdy powder-coated**

**steel cases. Proven 100,000-fold in workshops.**

For socket sets our test mechanics prefer steel cases: They are sturdy and preminently compact – a lot of tools, clearly arranged, requiring small space.

A chart for threads from M 1.6 – M 24 with related tightening torque is durably fixed inside the lid.



With distortion-free, indestructible trays of injected POLYPROPYLENE. Oil and acid resistant and easy to clean. With easy-to-read and durable marking of all socket sizes!

**29-piece socket set for powerful mechanical work. With 1/2" ratchet.**

Sockets from 8 – 34mm (the latter for M 22 according to the new ISO standard). Deep sockets in sizes 13 – 17 and 19mm for protruding bolts. Spark plug sockets 16 and 21mm. See photo for full contents.

**NO 23 000**

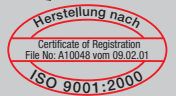

**56-piece set with 1/4" and 1/2" ratchets**

Contains sockets from 4mm to 32mm and 16/21mm spark plug sockets, screwdriver bits with square drive for slotted, Phillips, TX (with frontal hole) and Allen sockets and 1.25 – 1.5 – 2 – 2.5 and 3mm angled Allen keys. See photo for full contents.

**NO 23 040**



**27-piece automotive socket set with 1/4" and 1/2" ratchets**

Suitable for all common sizes between 6mm and 32mm. Also contains 16 and 21mm spark plug sockets. See photo for full contents.

**NO 23 020**

**Sensible combinations ranging from fine mechanics to powerful use! Forged of chrome**

**For clearly legible spanner widths. In sturdy powder-coated steel cases with highly**

**PROXXON**  
**INDUSTRIAL**



Screwdriver handle with 1/4" square drive. 1/4" rear end connector to fit a ratchet or a T-bar.



**36-piece precision engineer's set with 1/4" ratchet**

Includes 4 – 13mm sockets, screwdriver bits with square drive for slotted, Phillips, TX (with frontal hole) and Allen sockets as well as 1.25 – 1.5 – 2 – 2.5 and 3mm angled Allen keys.  
[See photo for full contents.](#)

**NO 23 080**



**39-piece screwdriver set with 1/4" ratchet and magnetic holder**

For use with a drilling machine: 4 – 14mm sockets 1/4" drive (6.3mm). Includes 16 high quality alloy Allen key bits and adapters for male hex and square bits (magnet to socket adapter) and female hex and square bits (ratchet to screwdriver bit adapter) and 1.25 – 1.5 – 2 – 2.5 and 3mm angled Allen keys.  
[See photo for full contents.](#)

**NO 23 070**

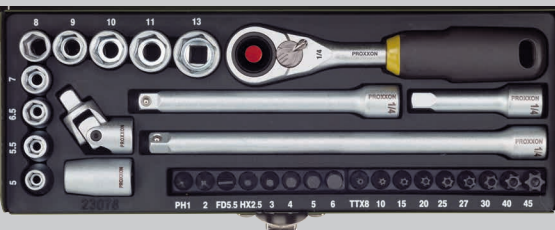

**32-piece precision engineer's socket set with 1/4" MICRO compact ratchet and sockets with strong magnetic inserts.**



Sockets from 5 – 13mm. In addition one each extension 50, 100 and 150mm: Nuts and screws are held securely even when working in tubes or pipes. 17 standard bits (25mm) made of high alloy special steel. Also includes hexagon/square female adapter.  
[See photo for full contents.](#)

**NO 23 078**



**24-piece compact socket set with 3/8" ratchet**

For 6 – 24mm. Including spark plug sockets 16 – 18 and 21mm.  
[See photo for full contents.](#)

**NO 23 110**



**65-piece super compact socket set with 3/8" ratchet**

Sockets from 6 – 24mm. Deep sockets for protruding bolts 10 – 13 – 15 and 17mm. Spark plug sockets 14 – 16 – 18 and 19mm. Screwdriver bits with square drive for HX, TX and XZN screws. 8 angled keys: HX 1.25 – 1.5 – 2 – 2.5 and 3mm as well as TX 6 – 8 and 10.  
[See photo for full contents.](#)

**NO 23 112**

**mium-vanadium steel 31 CrV3. Laser labelling:**

**flexible insert.**

**DIN  
ISO**



**24-piece TX socket set**

**This set contains 1/4" drive (6.3mm) TX sockets in sizes TX8 to TX30 (with frontal hole) and external TX sizes E4 to E10 (all suitable for tightening torques up to 25Nm).**

**1/2" drive (12.5mm) TX sockets in sizes TX40 – 60 and external TX E12 to E20 (for tightening torques from 25 to 135Nm) and three offset TX spanners – the TX6, 8 and 10.**

See photo for full contents.

**NO 23 102**



**29-piece Specialty TX socket and TX socket bit set**

**TTX-sockets for 1/4"-square drive (6.3mm)**

For tightening torques up to 10Nm: TTX 10 – 30. TX bit sockets in sizes E 4 – 5 – 6 – 8 and 10. **For 1/2"-square drive (12.5mm)**

For tightening torques from 25 to 135Nm: TX sockets in sizes 30 – 60 (short version: 55mm) and sizes 40 –60 (long version: 100mm). TX bit sockets in sizes E12 – 20 and three offset TX spanners – the TX6, 8 and 10.

**NO 23 103**



**18-piece special set for Allen screws**

**For 1/4" square drive (6.3mm) and tightening torques up to 25Nm.** Sizes 2 – 6mm.

**For 1/2" square drive (12.5mm) and tightening torques from 25 – 210Nm:** sizes 6 – 14mm (short version 55mm) and sizes 5 – 12mm (long version 100mm). See photo for full contents.

**NO 23 100**



**18-piece special set for XZN multi-toothed screws**

For motor (cylinder head), drive shafts, rear axles. Includes 1/2"-square drive. Screwdriver bits 5 – 14mm in normal version (55mm) and 6 – 14mm in extra-long version (100mm). Also includes outside double-hexagon inserts 9 – 21mm.

**NO 23 296**

**For inch screw sizes from 5/32" to 1 1/8".**



**36-piece special socket set for inch screws**

**Sockets for 1/4" square drive (6.3mm)**

5/32" – 3/16" – 7/32" – 1/4" – 9/32" – 5/16" – 11/32" – 13/32" – 7/16" – 1/2" – 9/16" HX-screwdriver bits 1/8" – 5/32" – 3/16" – 1/4".

**Sockets for 1/2" square drive (12.5mm)**

3/8" – 7/16" – 15/32" – 1/2" – 9/16" – 19/32" – 5/8" – 21/32" – 11/16" – 3/4" – 13/16" – 7/8" – 15/16" – 1" – 1 1/8".

Includes five bent Allen keys sizes 0.05" – 1/16" – 5/64" – 3/32" – 1/8". 1/4 -adapter.

**NO 23 114**

**Six popular socket sets in compact plastic cases.**

**Solid, sturdy tray and snap-lock.**

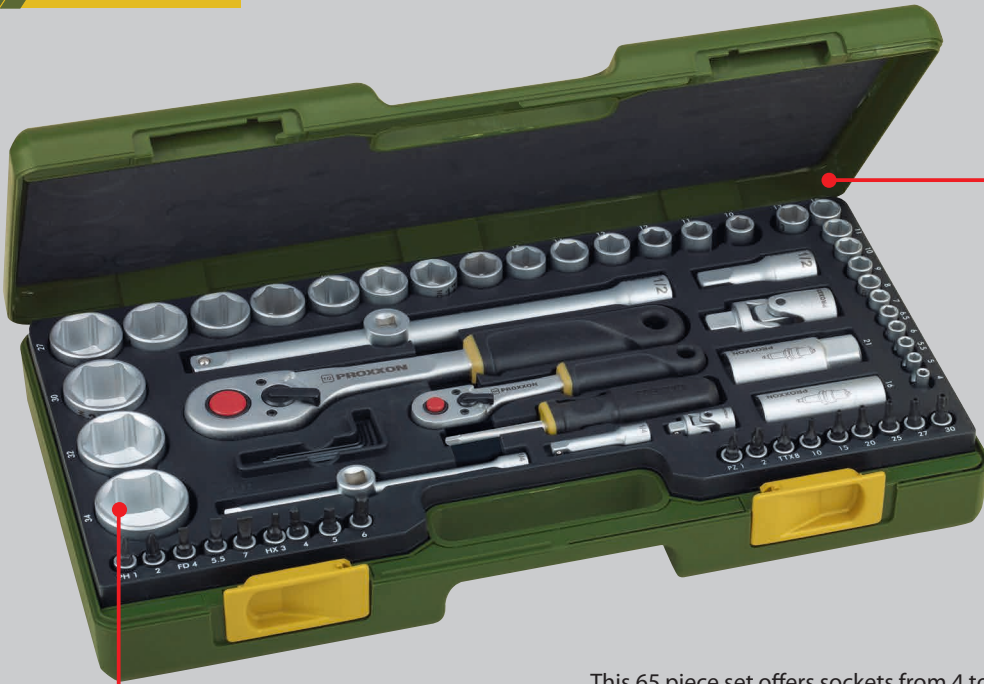

Composition and design copyright by PROXXON.



**65-piece complete set with 1/4" and 1/2" baton ratchets.**

With 34mm socket (according to new ISO standard for M 22).

This 65 piece set offers sockets from 4 to 34mm, as well as 16 and 21mm spark plug sockets. Screwdriver bits with square drive for slotted, Phillips, TX (with frontal hole) and Allen sockets. Angled Allen keys 1.25 – 1.5 – 2 – 2.5 and 3mm. Four extensions, one screwdriver handle with square drive, two universal joints.

See photo for full contents.

**NO 23 286**

**65-piece complete set for imperial sizes with 1/4" and 1/2" baton ratchets**



Sockets from 5/32" – 1 3/8". Spark plug sockets 5/8" and 13/16". Screw-driver bits with square drive for slotted, Phillips, TX (with frontal hole) and Allen screws. Five angled Allen keys from 0.05" to 1/8". Four extensions. Two universal joints. Screwdriver handle with square drive.



**NO 23 294**

**For inch screw sizes from 5/32" to 1 3/8".**

**47-piece compact set with 3/8" baton ratchet**



This 47 piece set offers sockets from 6 – 24mm. Deep sockets 10 – 17mm for protruding bolts. Spark plug sockets for 14, 16, 18 and 21mm. Screwdriver bits with square drive for Allen screws 4 – 10mm and TX screws (20 – 45). Two extensions. Universal joint. Five angled Allen keys 1.25 – 1.5 – 2 – 2.5 and 3mm.

See photo for full contents.

**NO 23 282**

Including the robust and fine-toothed baton ratchet for powerful use.

Quick-release mechanism at the push of a button.

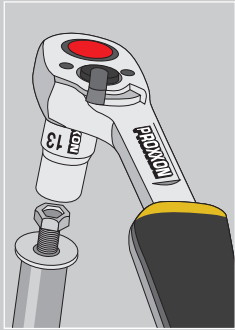

**DIN**  
**ISO**



Asymmetrical shape improves view when attaching to nut or bolt head.

Perfect toothing and reliable reverse mechanism. Several of the 72 teeth engage simultaneously for transferring also high torques.



**20-piece specialty socket set with deep sockets**



**With 1/4" square drive (6.3mm)**

for torques under 25Nm: hexagonal sockets for 4 – 5 – 5.5 – 6 – 7 – 8 – 9 – 10 – 11 and 12mm.

**With 1/2" square drive (12.5mm)**

for torques over 25Nm: 13 – 14 – 15 – 16 – 17 – 18 – 19 – 20 – 21 – 22 and 24mm. All parts are matt chrome-plated and are clearly marked with sizes.

See photo for full contents.

**NO 23 292**

**50-piece precision engineer's set with 1/4" baton ratchet**



This set includes sockets from 4 – 13mm, deep sockets from 6 – 10mm for protruding bolts and screwdriver bits with square drive for slotted, Phillips, Allen and TX (with frontal hole) screws. It also has external TX sizes E4 – 10, universal joint, 2 extensions, screwdriver handle with square drive and 1.25 – 1.5 – 2 – 2.5 and 3mm angled Allen keys.

See photo for full contents.

**NO 23 280**

**42-piece specialty set for TX and Allen screws**



**With 1/4" square drive (6.3mm)**

(for tightening torques up to 25Nm): Screwdriver bits for Allen screws sizes 2 – 6mm and screwdriver bits TX8 – TX40 (with frontal hole) as well as external TX E4 to E10.

**With 1/2" square drive (12.5mm)**

(for tightening torques from 25 – 210Nm): Screwdriver bits for Allen screws sizes 7 – 14mm (short version, 55mm) and sizes 6 – 12mm (long version, 100mm), for TX screws sizes 45 – 60 (short version) and for external TX sizes E12 to E20. Includes 5 angled head Allen keys in 1.25 – 1.5 – 2 – 2.5 and 3mm.

See photo at left for full contents.

**NO 23 290**

**NO 23 650: For 25 years this has been a classic among toolboxes world-wide.**

**Featuring first class assembly tools. Now in its 7th generation.**

**PROXXON**  
**INDUSTRIAL**

**DIN**  
**ISO**



**SlimLine-combination spanners** from 6 – 19mm. 14 spanners (with sizes 16 and 18, as per ISO for screws M 10 and M 12).

**1/2"-sockets:** 14 instead of 10 sockets (11, 16, 18 and 21mm have been added).

**Locksmith's hammer** (300g), with graphite handle for superior vibration damping, handy non-slip grip.

The selection of 16 and 21mm **spark plug sockets** was enlarged joining size 18mm, which has become increasingly important.

**FLEX-DOT - Screwdrivers**  
- 3 – 5,5 and 8  
+ 1 – 2

**KNIPEX**  
**Combination pliers**  
80mm.

**Reversible ratchet**  
with release mechanism.

**Water pump pliers**  
with box joint.

**KNIPEX**  
**8-piece pocket Allen key**  
(HX 1.5 – 8mm) and  
TX key (TX 9 – 40) sets.

### **Automotive and universal tool set**

Combination spanners from 6 – 19mm. 1/2" sockets from 8 – 24mm. Spark plug sockets 16 – 18 and 21mm. Automotive headlight tester with cord and crocodile clip (for car electrical systems). See photo for full contents. Each tool has its proper place – organized forever!

**NO 23 650**



*PROXXON design by Helmut Scholz: A high-quality POLYPROPYLENE tool case without frills. Treadable, shock-proof, fuel and acid resistant.*

**The compact companion for mobile use.**

**With tools of the finest quality.**

**DIN  
ISO**

**Universal tool bag.  
The most essential hand tools in a functional zipper bag.**



*Extremely compact!  
Exterior dimensions: 335 x 295 x 60mm.*

**FLEX-DOT  
Screwdrivers**

- ⊖ 3 – 5,5
- ⊕ 1 – 2

**Voltage tester**  
as per VDE 0680

**Combination pliers 180mm**

**Water pump pliers 250 mm**



**1/4" wrench  
sockets**  
4 – 14mm

**Bent Allen key ball head set**  
HX 1.5 – 10mm

**Hexagon bits**

- ⊕ 1 – 2 – 3
- ⊖ 4 – 5,5 – 6,5
- ⊕ 3 – 4 – 5 – 6
- ⊕ 8 – 10 – 15 – 20 – 25 – 30

**Locksmith's hammer**  
300g, with graphite handle

**SlimLine  
Ring/open-ended spanner**  
from 8 – 10 – 13 – 17

**1/4"-ratchet and  
Screwdriver handle**

**Each piece in its own fixed place:  
Sturdy tool board and high-quality foam insert with clear markings.**

1/4" ratchet (forged from a single piece). Wrench sockets 1/4" from 4 – 14mm incl. extension 100mm and screwdriver handle. Magnet holder and 1 adapter each hexagon/square and hexagon socket/square socket. 16 hexagonal bits made of high-alloy special steel. *SlimLine*

ring/open-ended spanner 8 – 17. Bent Allen key set HX 1.5 to 10mm. Ball-peen hammer 300 g with glass-fibre reinforced graphite handle. See photo for full contents.  
**NO 23 670**

# The L-BOXX-system: Organisation and safety in storage and transport

for professional craftsmen.



69 high quality tools placed ready to hand!

L-BOXX® -system L 102 (extremely flat!)



Store neatly, quickly and smoothly and transport safely. Compatible with numerous in-vehicle-equipment-systems of well-known brands. Outer dimensions: 445 x 358 x 118mm. Tool panel pouch and foam inlay made of high quality materials.



## Craftman's universal tool set in proven L-BOXX-system

14 sockets 1/2" (12.5mm) 8 – 24mm, standard ratchet 1/2", universal joint, extensions 125 and 250mm, 4 deep sockets 10 – 19mm, 15 SlimLine combination spanners 6 – 21mm, MicroSpeeder ratchet spanners 10 x 13 and 17 x 19mm, 5 slot screwdrivers 3 – 6.5mm, Phillips PH 1 and PH 2, voltage tester, pocket key sets HX and TX

(9-piece each), KNIPEX combination pliers 180mm and KNIPEX water pump pliers 250mm, Locksmith's hammer (300g) with graphite handle.

NO 23 660

1/4"  
6.3mm

**Ratchets, sockets and accessories for delicate projects.**

**All of chrome vanadium steel 31 CrV 3.**

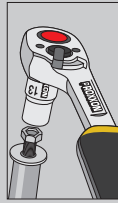

**Baton ratchet 1/4": Our sturdy ratchet!**

Fine tooth drive: Several of the 72 teeth engage simultaneously for transferring high torques. Reverse lever for ratcheting direction. Quick-release button for ejecting sockets. Head and shaft forged from one CrV steel billet. Double nickel plated with matt chrome plated finish. Grip of oil and acid-resistant TPR (thermoplastic rubber) with practical hole for hanging up.

**NO 23 330**

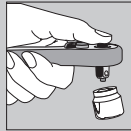

**Ratchet 2000 1/4": Our extremely flat ratchet!**

Precision ratchet drive for long service life and high torque transmission. Reverse lever for ratcheting direction. Quick-release button for releasing sockets instantly. With handy, soft-touch Dupont HYTREL grip and practical hole for hanging up.

**NO 23 170**



**Standard ratchet 1/4": Proven many times over!**

With reverse feature directly on ratchet mechanism. Several of the 52 teeth engage simultaneously for transferring extremely high torques. Quick-release button for ejecting sockets instantly. Head and shaft forged from one piece of CrV steel. Double nickel plated with matt chrome plated finish. Grip of oil and acid-resistant TPR (thermoplastic rubber) with practical hole for hanging up.

**NO 23 092**



**Standard ratchet 1/4": With flexible head!**

Head can be locked in 6 positions through 90° at the push of a button. Ideal where space is at a premium. Otherwise same as standard ratchet 1/4" (NO 23 092) described above.

**NO 23 074**

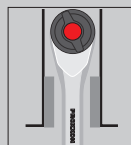

**ROTARY-ratchet 1/4": With additional offset-screwdriver function.**

The rotating grip design allows for pre-tensioning in abutment to one side. Then a few millimetres of standard ratcheting action is sufficient for loosening or tightening. Fine tooth drive (52 teeth) with convenient drive direction switch. Sockets are held firmly in place until the quick release button is activated.

**NO 23 082**

**MICRO ratchets for tricky work and where space is tight! For screwing in the engine compartment, under the dashboard or on the airbag, for working on the air conditioning system, inside the car body, the sun roof etc.**



**MICRO compact ratchet with 1/4" square drive.**

With extremely slim head (23 x 12mm). Fine-toothing: Many of the 72 teeth engage simultaneously for transferring extremely high torques. Reverse lever for ratcheting direction. Release mechanism: unlocking the sockets at the push of a button. Forged from CrV steel, double nickel plated with matt chrome plated finish. Grip of oil- and acid-resistant TPR (Thermoplastic Rubber). Total length 120mm. With practical hole for hanging up.

**NO 23 160**



**MICRO bit ratchet with 1/4" hexagonal adapter**

For 1/4" standard bits. With magnetic insert. Distance between reverse lever and bit end only 30mm. Technology and application identical to the 1/4" MICRO compact ratchet described above.

**NO 23 158**



**1/4"**  
6.3mm

**Sockets and accessories for delicate projects.**

**All of chrome vanadium steel 31 CrV 3.**

|   |   | Size  | Part No  |
|---|---|---|--|
|     | <b>1/4" sliding T-bar</b>   | 100mm   | 23 704   |
|     | <b>1/4" extension</b>   | 50mm<br>100mm<br>150mm  | 23 707<br>23 708<br>23 705   |
|     | <b>1/4" flexible extension</b>  | 150mm   | 23 706   |
|    | <b>1/4" universal joint</b>   |   | 23 709   |
|    | <b>1/4" magnetic holder for hexagonal bits</b><br>with male and female HX shafts. Ideal for working with electric screwdrivers and drills.  |   | 23 703   |
|  | <b>1/4" drill adapter</b><br>for 1/4"-sockets   |   | 23 700   |
|   | <b>Combination-Adaptor</b> with 1/4"-square and 1/4"-hexagon standard bits receptacle<br>For use with 1/4" sockets and 1/4" hexagon standard bits (6.3mm) on cordless screwdrivers and electric drilling machines. Choice between the two options simply by sliding the sleeve. |   | 23 783   |
|   | <b>1/4" drive screwdriver handle</b> with 1/4" connector at rear end, 140mm long  | 140mm   | 23 702   |
|   | <b>1/4" adapter for hexagonal bits</b> (DIN 3126) female square to female hexagon   |   | 23 780   |
|   | <b>1/4" adapter</b> 1/4" female square to 3/8" male square  |   | 23 782   |
|   | <b>1/4" adapter</b> with 1/4" male square to 1/4" male hexagon.   |   | 23 701   |
|  | <b>1/4" sockets</b><br>Made of CrV steel. Total length 25mm.  | 4mm<br>4.5mm<br>5mm<br>5.5mm<br>6mm<br>6.5mm<br>7mm<br>8mm<br>9mm<br>10mm<br>11mm<br>12mm<br>13mm<br>14mm | 23 710<br>23 711<br>23 712<br>23 713<br>23 714<br>23 715<br>23 716<br>23 718<br>23 720<br>23 722<br>23 724<br>23 726<br>23 728<br>23 729 |



**1/4" deep sockets**  
 For long protruding bolts.  
 Made of CrV steel. Total length 50mm.

|       |        |
|-------|--------|
| 4mm   | 23 767 |
| 5mm   | 23 768 |
| 5.5mm | 23 769 |
| 6mm   | 23 770 |
| 7mm   | 23 772 |
| 8mm   | 23 774 |
| 9mm   | 23 776 |
| 11mm  | 23 778 |
| 12mm  | 23 777 |
| 13mm  | 23 775 |
| 14mm  | 23 779 |
|       | 23 773 |



**1/4" Allen socket bits, 33mm**  
 Head made of chrome-silicon-manganese-molybdenum steel.  
 Socket CrV steel.

|          |        |
|----------|--------|
| HX 2mm   | 23 744 |
| HX 2.5mm | 23 746 |
| HX 3mm   | 23 743 |
| HX 4mm   | 23 745 |
| HX 5mm   | 23 747 |
| HX 5.5mm | 23 748 |
| HX 6mm   | 23 749 |
| HX 8mm   | 23 751 |



**1/4" female TX (TTX) sockets**  
 Made of CrV steel. Total length 25mm.

|      |        |
|------|--------|
| E 4  | 23 788 |
| E 5  | 23 790 |
| E 6  | 23 792 |
| E 7  | 23 793 |
| E 8  | 23 794 |
| E 10 | 23 796 |



**1/4" TTX screwdriver bits, 33mm (with frontal hole)**  
 Head made of chrome-silicon-manganese-molybdenum steel. Socket CrV steel.

|        |        |
|--------|--------|
| TTX 5  | 23 755 |
| TTX 6  | 23 752 |
| TTX 8  | 23 753 |
| TTX 10 | 23 754 |
| TTX 15 | 23 756 |
| TTX 20 | 23 758 |
| TTX 25 | 23 760 |
| TTX 27 | 23 761 |
| TTX 30 | 23 762 |
| TTX 40 | 23 764 |



**1/4" flat-blade screwdriver bits, 33mm**  
 Made of chrome-silicon-manganese-molybdenum steel. Socket CrV steel.

|          |        |
|----------|--------|
| FD 4mm   | 23 737 |
| FD 5.5mm | 23 739 |
| FD 7mm   | 23 741 |
| FD 8mm   | 23 742 |

**1/4" Phillips screwdriver bits, 33mm**  
 Made of chrome-silicon-manganese-molybdenum steel. Socket CrV steel.

|      |        |
|------|--------|
| PH 1 | 23 730 |
| PH 2 | 23 731 |
| PH 3 | 23 732 |



**1/4" Pozidriv screwdriver bits, 33mm**  
 Made of chrome-silicon-manganese-molybdenum steel. Socket CrV steel.

|      |        |
|------|--------|
| PZ 1 | 23 733 |
| PZ 2 | 23 735 |

**3/8"**  
10mm

**Ratchets, sockets and accessories, handy and compact  
for every user! 31 CrV 3 chrome-vanadium steel.**

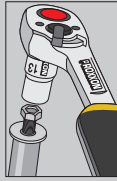

**Baton ratchet 3/8". Our sturdy ratchet!**

Fine tooth drive: Several of the 72 teeth engage simultaneously for transferring maximum torque. Reverse lever for ratcheting direction. Quick-release button for releasing sockets instantly. Head and shaft forged from one piece of CrV steel. Double nickel-plated with matt chrome-plated finish. Grip of oil and acid-resistant TPR (thermoplastic rubber) with practical hole for hanging up.

**NO 23 332**

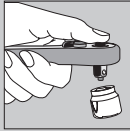

**Ratchet 2000 3/8". Our extremely flexible ratchet!**

Precision ratchet drive with 44 teeth for long service life and high torque. Reverse lever for ratcheting direction. Quick-release button for releasing sockets instantly. With handy, soft-touch Dupont HYTREL grip and practical hole for hanging up.

**NO 23 180**



**Standard ratchet 3/8". Proven many times over!**

With reverse feature directly on ratchet mechanism. Several of the 52 teeth engage simultaneously for transferring extremely high torque. Quick-release button for releasing sockets instantly. Head and shaft forged from one piece of CrV steel. Double nickel-plated with matt chrome-plated finish. Grip of oil and acid-resistant TPR (thermoplastic rubber) with practical hole for hanging up.

**NO 23 094**

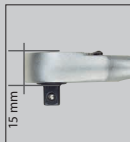

**MICRO compact ratchet 3/8". With extremely slim ratchet head!**

Fine tooth drive: Several of the 72 teeth engage simultaneously transferring extremely high torques. Reverse lever for ratcheting direction. Release mechanism: unlocking the sockets at the push of a button. Forged from CrV-steel, double nickel plated with matt chrome plated finish. Grip of oil- and acid-resistant TPR (Thermoplastic Rubber).

**NO 23 162**

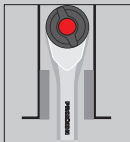

**ROTARY-ratchet 3/8". With additional offset-screwdriver function.**

The rotating grip design allows for pre-tensioning in abutment to one side. Then a few millimetres of standard ratcheting action is sufficient for loosening or tightening. Fine tooth drive (52 teeth) with convenient drive direction switch. Sockets are held firmly in place until the quick release button is activated.

**NO 23 083**



**3/8" extension with slide**  
Adapter to 3/8" male square and 1/2" female square.

| Size  | Part No |
|-------|---------|
| 200mm | 23 558  |



**3/8" extension**

|       |        |
|-------|--------|
| 75mm  | 23 554 |
| 150mm | 23 556 |



**3/8" universal joint**

23 560



**3/8" adapter**  
3/8" female to 1/4" male square (slide for 1/4" extension).

23 564

**3/8" adapter**  
3/8" female square drive to male 1/2" drive (slide for 1/2" extension).

23 566



**3/8" drill adapter**  
for 3/8"-sockets

23 562

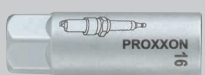

**3/8" spark plug socket**  
With TPR (thermoplastic rubber) insert for holding spark plugs. Length 64mm.  
**As above, length 70mm**

|      |        |
|------|--------|
| 16mm | 23 550 |
| 18mm | 23 551 |
| 19mm | 23 541 |
| 21mm | 23 552 |

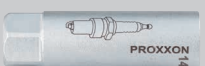

**3/8" spark plug socket**  
HX and double HX (BI-HX) spark plugs. Slim design (Ø 20mm). With TPR (thermoplastic rubber) insert for holding spark plugs. Length 64mm.

14mm 23 553



**3/8" sockets**  
Made of CrV steel.

|      |        |
|------|--------|
| 6mm  | 23 500 |
| 7mm  | 23 502 |
| 8mm  | 23 504 |
| 9mm  | 23 506 |
| 10mm | 23 508 |
| 11mm | 23 510 |
| 12mm | 23 512 |
| 13mm | 23 514 |
| 14mm | 23 516 |
| 15mm | 23 518 |
| 16mm | 23 520 |
| 17mm | 23 522 |
| 18mm | 23 523 |
| 19mm | 23 524 |
| 21mm | 23 526 |
| 22mm | 23 528 |
| 24mm | 23 530 |



**3/8" deep sockets**  
for protruding bolts.  
Made of CrV steel.  
Total length 46mm.

|      |        |
|------|--------|
| 8mm  | 23 532 |
| 9mm  | 23 534 |
| 10mm | 23 536 |
| 11mm | 23 538 |
| 12mm | 23 540 |
| 13mm | 23 542 |
| 14mm | 23 543 |

As above, total length 64mm.

|      |        |
|------|--------|
| 15mm | 23 544 |
| 17mm | 23 546 |
| 18mm | 23 548 |
| 19mm | 23 549 |
| 22mm | 23 545 |
| 24mm | 23 547 |



**3/8" Allen socket bits, 50mm**  
Allen key made of chrome-silicon-  
manganese-molybdenum steel.  
Socket CrV steel.

|         |        |
|---------|--------|
| HX 4mm  | 23 575 |
| HX 5mm  | 23 576 |
| HX 6mm  | 23 578 |
| HX 7mm  | 23 579 |
| HX 8mm  | 23 580 |
| HX 9mm  | 23 577 |
| HX 10mm | 23 581 |
| HX 11mm | 23 573 |



**3/8" external TX socket**  
Made of CrV steel.

|      |        |
|------|--------|
| E 6  | 23 612 |
| E 7  | 23 613 |
| E 8  | 23 614 |
| E 10 | 23 616 |
| E 12 | 23 618 |
| E 14 | 23 620 |
| E 18 | 23 624 |



**3/8" TX socket bits, 50mm**  
Head made of chrome-silicon-manganese-  
molybdenum steel. Socket CrV steel.

|       |        |
|-------|--------|
| TX 10 | 23 583 |
| TX 15 | 23 582 |
| TX 20 | 23 584 |
| TX 25 | 23 585 |
| TX 27 | 23 586 |
| TX 30 | 23 587 |
| TX 40 | 23 588 |
| TX 45 | 23 589 |
| TX 50 | 23 590 |



**3/8" Phillips screwdriver bits, 50mm**  
Bit made of chrome-silicon-manganese-  
molybdenum steel. Socket CrV steel.

|      |        |
|------|--------|
| PH 1 | 23 594 |
| PH 2 | 23 595 |
| PH 3 | 23 596 |



**3/8" spline socket bits, 50mm**  
for XZN bolts. Bit made of chrome-silicon-  
manganese-molybdenum steel. Socket CrV steel.

|       |        |
|-------|--------|
| VZ 5  | 23 628 |
| VZ 6  | 23 629 |
| VZ 8  | 23 631 |
| VZ 10 | 23 633 |

**1/2"**  
12.5mm

**Ratchets, sockets and accessories for the most demanding situations. 31 CrV 3 chrome-vanadium steel.**

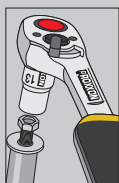

**Baton ratchet 1/2". Our sturdy ratchet!**

Fine tooth drive: Several of the 72 teeth engage simultaneously for transferring maximum torque. Reverse lever for ratcheting direction. Quick-release button for releasing sockets instantly. Head and shaft forged from one piece of CrV steel. Double nickel-plated with matt chrome-plated finish. Grip of oil and acid-resistant TPR (thermoplastic rubber) with practical hole for hanging up.

**NO 23 334**

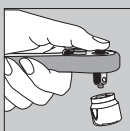

**Ratchet 2000 1/2". Our extremely flexible ratchet!**

Precision ratchet drive with 44 teeth for long service life and high torque transmission. Reverse lever for ratcheting direction. Quick-release button for releasing sockets instantly. With handy, soft-touch Dupont HYTREL grip and practical hole for hanging up.

**NO 23 190**

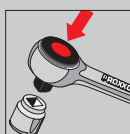

**Standard ratchet 1/2". Proven many times over!**

With reverse feature directly on ratchet mechanism. Several of the 52 teeth engage simultaneously for transferring extremely high torque. Quick-release button for releasing sockets instantly. Head and shaft forged from one piece of CrV steel. Double nickel-plated with matt chrome-plated finish. Grip of oil and acid-resistant TPR (thermoplastic rubber) with practical hole for hanging up.

**NO 23 096**

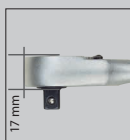

**MICRO compact ratchet 1/2". With extremely slim ratchet head!**

Fine tooth drive: Several of the 72 teeth engage simultaneously transferring extremely high torques. Reverse lever for ratcheting direction. Release mechanism: unlocking the sockets at the push of a button. Forged from CrV-steel, double nickel plated with matt chrome plated finish. Grip of oil- and acid-resistant TPR (Thermoplastic Rubber).

**NO 23 164**

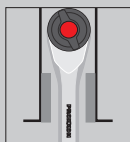

**ROTARY-ratchet 1/2". With additional offset-screwdriver function.**

The rotating grip design allows for pre-tensioning in abutment to one side. Then a few millimetres of standard ratcheting action is sufficient for loosening or tightening. Fine tooth drive (52 teeth) with convenient drive direction switch. Sockets are held firmly in place until the quick release button is activated.

**NO 23 084**



**Extra long lever with universal joint and ratchet mechanism**

For effortless loosening of tightly locked screws. Robust ratchet mechanism (60 teeth) with knurled ring offering reverse operation. Grip made of oil and acid resistant TPR (Thermoplastic Rubber).

**NO 23 090** Total length 43cm



**1/2" extension with slide**  
With adapter from 1/2" male to 3/8" female.

Size Part No

250mm 23 457



**1/2"-extension**

64mm 23 452  
125mm 23 454  
250mm 23 456



**1/2"-female to 3/8" male square drive**  
(sliding part for 3/8" extension)

23 458



**1/2"-universal joint**

23 450



**drill adapter**  
for 1/2" sockets

23 460



**1/2" spark plug sockets**  
With TPR (thermoplastic rubber) insert for holding spark plugs. Length 65mm.  
**As above**, length 70mm

|      |        |
|------|--------|
| 16mm | 23 442 |
| 18mm | 23 443 |
| 19mm | 23 445 |
| 21mm | 23 444 |



**1/2"-spark plug sockets**  
With TPR (thermoplastic rubber) insert for holding spark plugs. Length 65mm.  
**As above**, length 70mm

|      |        |
|------|--------|
| 16mm | 23 392 |
| 18mm | 23 394 |
| 19mm | 23 395 |
| 21mm | 23 396 |



**1/2"- sockets**  
With reduced drive and diameter (19mm and over).  
Made of CrV steel.

|      |        |
|------|--------|
| 8mm  | 23 400 |
| 9mm  | 23 402 |
| 10mm | 23 404 |
| 11mm | 23 406 |
| 12mm | 23 408 |
| 13mm | 23 410 |
| 14mm | 23 412 |
| 15mm | 23 414 |
| 16mm | 23 415 |
| 17mm | 23 416 |
| 18mm | 23 417 |
| 19mm | 23 418 |
| 20mm | 23 419 |
| 21mm | 23 420 |
| 22mm | 23 422 |
| 23mm | 23 423 |
| 24mm | 23 424 |
| 27mm | 23 426 |
| 30mm | 23 428 |
| 32mm | 23 430 |
| 34mm | 23 431 |
| 36mm | 23 429 |



**1/2"-deep sockets**  
For protruding bolts.  
Made of CrV steel. Total length 79mm.

|      |        |
|------|--------|
| 10mm | 23 355 |
| 11mm | 23 356 |
| 12mm | 23 357 |
| 13mm | 23 358 |
| 14mm | 23 359 |
| 15mm | 23 360 |
| 16mm | 23 361 |
| 17mm | 23 362 |
| 18mm | 23 363 |
| 19mm | 23 364 |
| 21mm | 23 365 |
| 22mm | 23 366 |
| 24mm | 23 367 |

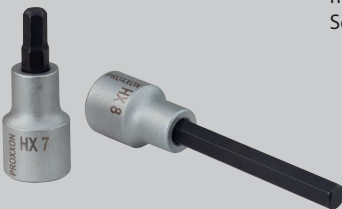

**1/2"-Allen socket bits, 55mm**  
Allen key made of chrome-silicon- manganese-molybdenum steel.  
Socket CrV steel.

|         |        |
|---------|--------|
| HX 5mm  | 23 476 |
| HX 6mm  | 23 477 |
| HX 7mm  | 23 478 |
| HX 8mm  | 23 479 |
| HX 9mm  | 23 463 |
| HX 10mm | 23 480 |
| HX 11mm | 23 465 |
| HX 12mm | 23 481 |
| HX 14mm | 23 482 |
| HX 17mm | 23 471 |
| HX 19mm | 23 473 |

**1/2"-Allen socket bits, 100mm**  
Allen key made of chrome-silicon-manganese-molybdenum steel.  
Socket CrV steel.

|         |        |
|---------|--------|
| HX 5mm  | 23 484 |
| HX 6mm  | 23 475 |
| HX 7mm  | 23 485 |
| HX 8mm  | 23 486 |
| HX 9mm  | 23 466 |
| HX 10mm | 23 487 |
| HX 11mm | 23 467 |
| HX 12mm | 23 483 |
| HX 14mm | 23 468 |

**1/2"**  
12.5 mm



**1/2" external TX socket**  
Hergestellt aus CrV-Stahl.

| Size | Part No |
|------|---------|
| E 10 | 23 380  |
| E 12 | 23 382  |
| E 14 | 23 384  |
| E 16 | 23 386  |
| E 18 | 23 388  |
| E 20 | 23 390  |
| E 24 | 23 391  |



**1/2" TX socket bits, 55mm**  
Head made of chrome-silicon-manganese-molybdenum steel. Socket CrV steel.

|       |        |
|-------|--------|
| TX 20 | 23 488 |
| TX 25 | 23 489 |
| TX 27 | 23 490 |
| TX 30 | 23 491 |
| TX 40 | 23 492 |
| TX 45 | 23 493 |
| TX 50 | 23 494 |
| TX 55 | 23 446 |
| TX 60 | 23 447 |
| TX 70 | 23 448 |

**1/2" TX socket bits, 100mm**  
Head made of chrome-silicon-manganese-molybdenum steel. Socket CrV steel.

|       |        |
|-------|--------|
| TX 40 | 23 495 |
| TX 45 | 23 496 |
| TX 50 | 23 497 |
| TX 55 | 23 498 |
| TX 60 | 23 499 |



**1/2" spline socket bits, 55mm**  
for XZN bolts. Bit made of chrome-silicon-manganese-molybdenum steel. Socket CrV steel.

|       |        |
|-------|--------|
| VZ 5  | 23 318 |
| VZ 6  | 23 319 |
| VZ 8  | 23 321 |
| VZ 10 | 23 323 |
| VZ 12 | 23 325 |
| VZ 14 | 23 327 |
| VZ 16 | 23 328 |
| VZ 18 | 23 329 |

**1/2"-spline socket bits, 100mm**  
for XZN bolts. Bit made of chrome-silicon-manganese-molybdenum steel. Socket CrV steel.

|       |        |
|-------|--------|
| VZ 6  | 23 370 |
| VZ 8  | 23 371 |
| VZ 9  | 23 376 |
| VZ 10 | 23 372 |
| VZ 12 | 23 373 |
| VZ 14 | 23 374 |
| VZ 16 | 23 377 |
| VZ 18 | 23 378 |



**1/2"- sockets for XZN-screws, 12-pt**  
Made of CrV steel.

|      |        |
|------|--------|
| 9mm  | 23 304 |
| 10mm | 23 305 |
| 12mm | 23 307 |
| 18mm | 23 311 |
| 19mm | 23 312 |
| 21mm | 23 314 |

**3/4"**  
19mm

## Socket set with 3/4" square drive

**14-piece socket set with 3/4" square drive.**  
**For lorries, tractors and other machinery.**

10 sockets from 22 – 50mm. 520mm ratchet (72 teeth) with quick-release button for releasing sockets instantly. Sliding T-bar (500mm). Each one extension of 200mm and 400mm.

**NO 23 300**



**Workshop special sets for long bolts and screws. With forged, short tubular hexagon box spanners and externally gripping ratchet.**



**14-piece special set 13 to 27mm**

With reversible ratchet, TPR (thermoplastic rubber) grip, 55mm extension (open construction as well) and adapter with 1/2" square (12.5mm). In robust steel box (powder coated) with strong plastic tray.

**NO 23 604**

**13-piece special set 5.5 to 14mm**

With reversible ratchet, TPR (thermoplastic rubber) grip, 55mm extension (open construction as well) and adapter with 1/4" (6.3mm) square. In robust steel box (powder coated) with strong plastic tray.

**NO 23 602**

**Adjustable wrenches forged from CrV steel. According to DIN 3117 / ISO 6787.**

Extra-long version with soft-finish skin-friendly handle made of oil and acid resistant TPR (thermoplastic rubber) with hanging hole. Slim head with ground jaws. Accurate control of flexible jaw with smooth-running adjustment via knurled screw. Easy to read millimetre scale for defining size across flats and measuring work pieces.

jaw width

|                  |        |        |
|------------------|--------|--------|
| <b>NO 23 990</b> | RG 200 | 24.5mm |
| <b>NO 23 992</b> | RG 250 | 29mm   |
| <b>NO 23 994</b> | RG 300 | 34mm   |



**IMPACT socket sets for wheel nuts. Sockets with plastic cover and plastic stop insert prevent aluminium wheel rims from damage. Now also available in extra long version (130mm).**

For use with pneumatic screwdrivers 1/2". Made of high alloy special steel for superior wear resistance and a maximum torque of 500Nm. One piece each 17 – 19 and 21mm in sturdy steel box (powder coated).

|                  |                     |       |
|------------------|---------------------|-------|
| <b>NO 23 938</b> | standard version,   | 85mm  |
| <b>NO 23 970</b> | extra long version, | 130mm |

**IMPACT sockets, individually. Standard length: 85mm.**

|                  |         |
|------------------|---------|
| <b>NO 23 962</b> | Size 17 |
| <b>NO 23 964</b> | Size 19 |
| <b>NO 23 966</b> | Size 21 |

**IMPACT sockets, individually. Extra long version: 130mm.**

|                  |         |
|------------------|---------|
| <b>NO 23 972</b> | Size 17 |
| <b>NO 23 974</b> | Size 19 |
| <b>NO 23 976</b> | Size 21 |



Herstellung nach  
Certificate of Registration  
File No. A110048 vom 09.02.01  
ISO 9001:2000

**MicroClick torque wrenches. Precision tools with high accuracy (tolerance of +/- 3%)**

**Calibrated and inspected piece by piece. Including test certificate.**



**Automatic quick-release: Clearly audible and tangible click sign**



Clearly legible analogue display for simple pre-selection of the desired torque.

Ergonomically shaped handle allows for automatically gripping it in a centric position. Important for obtaining an exact release torque.

Additional micro-scale for fine adjustment.

Simple pre-setting of the torque by turning the knurled ring at the end of the handle, fixing it by sliding it into position.



**Note:**  
IMPACT sockets for wheel nuts are featured on page 19!

Sturdy, oval steel shaft with rust-protective finish: double nickel and subsequent matt-finished chrome-plating.

Piece by piece calibration and final inspection. With permanent laser-marked serial number identifying the product.

### **MicroClick MC 320. For 60 – 320Nm.**

With 1/2" square drive (12.5mm). Total length 610mm. Otherwise as described above.

**NO 23 354**

### **MicroClick MC 200. For 40 – 200Nm.**

With 1/2" square drive (12.5mm). Total length 530mm. Otherwise as described above.

**NO 23 353**

### **MicroClick MC 100. For 20 – 100Nm.**

With 3/8" square drive (10mm). Total length 430mm. Particularly suitable for motorcycles. Otherwise as described above.

**NO 23 351**

### **MicroClick MC 60. For 12 – 60Nm.**

With 3/8" square drive (10mm). Total length 370mm. Otherwise as described above.

**NO 23 350**

### **MicroClick MC 30. For 6 – 30Nm.**

With 1/4" square drive (6.3mm). Total length 335mm. Otherwise as described above.

**NO 23 349**



according to ISO 6789-1).

al on reaching the preselected torque.

Practical release mechanism: the socket is securely fixed and automatically released at the push of the button.

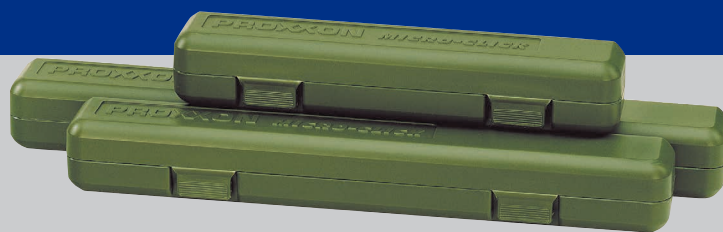

MicroClick torque wrenches are precision tools. They are packaged in a sturdy and practical plastic storage box.

**3/4"**  
19mm

**MicroClick-MC 500. For 100 – 500Nm.**

For repairs on small trucks, transporters and tractors. With 3/4" square drive (19mm). Ratchet mechanism with reversing lever for clockwise and anticlockwise rotation.

Sturdy steel shaft with rust-protective finish: double nickel and subsequent matt-finished chrome-plating. Piece by piece calibration and final inspection (including test certificate). Tolerance according to ISO 6789: +/- 3%.

Clearly legible analogue display with additional micro-scale for fine adjustment. Total length 820mm. Packaged in a practical plastic storage box.

NO 23 340



**Note:**

MicroClick torque screwdrivers MC 2 (0.4 to 2Nm), MC 5 (1 to 5Nm) und MC 10 (2 to 10Nm) as well as MicroClick torque wrench MC 15 (3 to 15Nm) are featured on page 23.

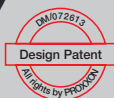

Tightening torques for bolt shanks with standard metric threads (DIN 13, Part 13) and head contact dimensions (DIN 912, 931, 934). The coefficient of friction was determined using an untreated and unplated bolt (ungreased, lightly oiled).

| mm    | HX        | INHX   | FM-TX     | M-TX     | XZN   | Nm <sup>1)</sup> |
|-------|-----------|--------|-----------|----------|-------|------------------|
| M 1,6 | SW 3,2    | HX 1,5 | TX 5      | -        | -     | 0,2              |
| M 2   | SW 4      | HX 1,5 | TX 6      | -        | -     | 0,35             |
| M 2,5 | SW 5      | HX 2   | TX 7; 8   | -        | -     | 0,8              |
| M 3   | SW 5,5    | HX 2,5 | TX 9; 10  | E 4      | -     | 1,3              |
| M 3,5 | SW 6      | HX 2,5 | TX 15     | E 4      | -     | 2                |
| M 4   | SW 7      | HX 3   | TX 20     | E 5; 6   | -     | 2,9              |
| M 5   | SW 8      | HX 4   | TX 25; 27 | E 6; 8   | -     | 6                |
| M 6   | SW 10     | HX 5   | TX 27; 30 | E 8; 10  | VZ 5  | 10,2             |
| M 7   | SW 11     | HX 5   | TX 40     | E 8; 10  | VZ 5  | 16               |
| M 8   | SW 13     | HX 6   | TX 45     | E 10; 12 | VZ 6  | 25               |
| M 10  | SW 16; 17 | HX 8   | TX 45; 50 | E 12; 14 | VZ 8  | 50               |
| M 12  | SW 18; 19 | HX 10  | TX 55     | E 14; 18 | VZ 10 | 86               |
| M 14  | SW 21; 22 | HX 12  | TX 60     | E 18; 20 | VZ 12 | 138              |
| M 16  | SW 24     | HX 14  | TX 70     | E 20     | VZ 14 | 215              |
| M 18  | SW 27     | HX 14  | TX 80     | E 24     | -     | 296              |
| M 20  | SW 30     | HX 17  | TX 90     | E 24     | -     | 420              |
| M 22  | SW 32; 34 | -      | -         | -        | -     | 573              |
| M 24  | SW 36     | HX 19  | -         | -        | -     | 725              |

<sup>1)</sup> Schraubenqualität 8.8; Gewindereizzahl j=0,14  
PROXXON SA • Haasberg 6 - 10 • L-6883 Wecker • info@proxxon.com

© copyright by **PROXXON**

# For safety and the accurate tightening torque: MicroClick precision tools.

## MicroClick torque screwdriver

Automatic short release when tightening screws: Clearly audible and tangible click signal when preselected torque is reached. The torque is set by turning the knurled ring on the end of the handle. The selected value is fixed by sliding in the ring. Clearly legible window scale.



### MicroClick MC 2. For 0.4 – 2Nm.

50 mm long slender shaft with magnetic holder for standard bits 1/4" (6.3mm). Includes adapter with 1/4" external hexagon head on 1/4" external square head for wrench sockets. Accuracy +/- 6%. Total length 170 mm. Weight 135g. **NO 23 343**

### MicroClick MC 5. For 1 – 5Nm.

Additional micro-scale for fine adjustment: 1 rotation = 1Nm. Scale ring with 0.1Nm graduations. With 1/4" square end (6.3 mm) for wrench sockets and attachable adapter with spring sleeve for form-locked holding of 1/4" standard bits (6.3mm). Accuracy +/- 6%. Total length 165mm. **NO 23 347**

### MicroClick MC 10. For 2 – 10Nm.

Fine adjustment: 1 rotation = 2Nm. Scale ring with 0.2Nm graduations. With front side 1/4" holding fixture for mounting a T-grip with slide (included in delivery). **NO 23 348**



**Note:**

A well-shaped ergonomic screwdriver handle allows for torques from 6 to 8Nm just by manual operation. For higher torques, the MC 10 has a 1/4" square connector on the rear end for fitting a lever (T-handle, ratchet).

## MicroClick torque wrench MC 60-Multi and MC 200-Multi. For clockwise and anticlockwise tightening.

Open-ended spanner attachments enable side access: For tightening of screws and sleeves at pipe connections, hydraulic lines, threaded rods. Automatic short release: clearly audible and tangible click signal when preselected torque is reached. Height Release accuracy as per DIN/ ISO 6789. Tolerance +/- 3%. With test certificate. Packed in practical plastic case.

**3/8"**  
10 mm



### MicroClick MC 60-Multi. For 12 – 60Nm.

Push-on tools with square end insert (9 x 12mm) for locking with spring pin: 10 open-ended spanners forged of CrV steel, in sizes 10 – 11 – 12 – 13

– 14 – 15 – 16 – 17 – 18 and 19m m. Ratchet head with 3/8" square end. **NO 23 341**

**1/2"**  
12.5 mm



### MicroClick MC 200-Multi. For 40 – 200Nm.

Push-on tools with square end insert (14 x 18mm) for locking with spring pin: 9 open-ended spanners forged of CrV steel, in sizes 13 – 14 – 15 – 17 – 19 – 22

– 24 – 27 and 30mm. Ratchet head with 1/2" square end (12.5mm). **NO 23 342**

**MicroClick torque wrench MC 15**  
**For 3 to 15Nm.**

Automatic quick-release when tightening screws: Clearly audible and palpable click signal when the selected torque is reached. Pre-setting of the torque by turning the knurled ring at the end of the handle, fixing it by sliding it into position. Clearly legible analogue scale display and additional micro scale for fine adjustment. Scale ring with 0.4Nm graduation. 1/4" square drive (6.3mm) with adapter for use of 1/4" standard screwdriver bits. Reverse lever for clockwise and anticlockwise rotation. Accuracy +/- 3%. Total length 195mm.

NO 23 345



MicroClick- torque wrenches are precision tools. They are packaged in a sturdy and practical plastic storage box.

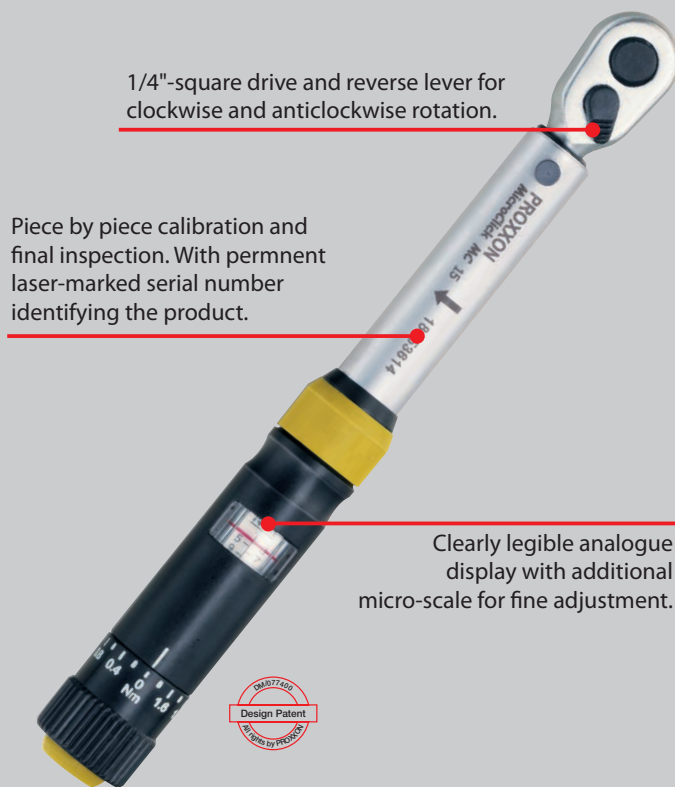

1/4"-square drive and reverse lever for clockwise and anticlockwise rotation.

Piece by piece calibration and final inspection. With permanent laser-marked serial number identifying the product.

Clearly legible analogue display with additional micro-scale for fine adjustment.



**Electronic torque wrench MC 100/E and MC 200/E**  
**For industry, trade and laboratories: Ideal for screw connections with obligatory documentation requirement. For right- and left-hand thread.**

Digital display for preselected units of measurement and results display: Ten different target torques can be preselected and stored. And also the desired tolerance (1 - 9%). Bluetooth interface: Connection with smartphone or tablet for operating and measured value documentation in real time. Piece by piece calibration and final inspection. With test certificate. Includes 3 AAA batteries.

**MC 100/E. For 10 – 100Nm.**  
3/8"-drive (10mm).

NO 23 337

**MC 200/E. For 20 – 200Nm.**  
1/2"-drive (12.5mm).

NO 23 338



LED indicator for visual control of the release.

Digital display for preselected units of measurement and results display.

Input keys for programming and retrieving the results.

Bluetooth interface for measured value export.

Vibration alarm in handle area for sensory release.



Real-time reporting via App.

## MicroSpeeder with ratchet mechanism on the ring end.

No swapping over: a real time saver! Extra long design.

PROXXON

INDUSTRIAL

The 72-teeth inner ring gear made of special high alloy steel allows ratcheting even when the spanner can only be moved through 5°. However, the torque transmission capacity far exceeds the DIN/ISO standards. CrV steel shaft with optimum surface protection: double nickel-plating and single matt-finished chrome-plating. Spanner sizes easy to read due to laser marking!



A very slim head provides shelter to the fully encapsulated drive.

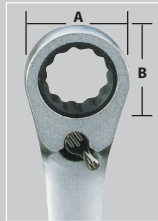

Compact design allows for minimal outer dimensions (A + B).



Where old generationspanners cannot be repositioned the Speeder's ratchet function takes over.

## MicroSpeeder in standard version (straight, slender design without reverse lever).



With ratchet mechanism on the ring end. No swapping over: a real time saver! Ideal for inserting into tight spaces. For removing engines, on automatic transmissions or rear axles, etc.

### MicroSpeeder in standard version, individually

|           |         |
|-----------|---------|
| NO 23 257 | Size 8  |
| NO 23 258 | Size 9  |
| NO 23 259 | Size 10 |
| NO 23 260 | Size 11 |
| NO 23 261 | Size 12 |
| NO 23 262 | Size 13 |
| NO 23 263 | Size 14 |
| NO 23 264 | Size 15 |
| NO 23 265 | Size 16 |
| NO 23 266 | Size 17 |
| NO 23 267 | Size 18 |
| NO 23 268 | Size 19 |
| NO 23 270 | Size 21 |
| NO 23 271 | Size 22 |
| NO 23 273 | Size 24 |

### 7-piece MicroSpeeder set in straight, slim design

One each 8 – 10 – 13 – 16 – 17 – 18 and 19mm in extra long design as featured. In a sturdy powder coated steel box.

NO 23 275



Straight design without reversing lever. The spanner is simply swapped over.

**10-piece MicroSpeeder set in foldable plastic holder.  
8 – 19mm.**



With ratchet mechanism and reverse lever on the ring end for clockwise and anticlockwise rotation. No swapping over: a real time saver. Ideally suited for working on flat surfaces due to its 15° offset ring side. Practical foldable holder offering a clearly marked place for storage of each spanner. The ideal companion for construction site work. Holder also provides holes for wall-mounting in the workshop. With clearly readable sizes. Organised forever!

One each in extra long design, sizes 8 – 10 – 11 – 12 – 13 – 14 – 16 – 17 – 18 and 19mm.

**NO 23 126**



**MicroSpeeder with reverse lever and 15° offset ring side.**



As the 15° offset ring makes turning over of the spanner impossible, the spanner offers a reverse lever. Its design makes it ideally suited for working on flat surfaces.

**MicroSpeeder with reverse lever, individually**

- NO 23 130** Size 8
- NO 23 131** Size 9
- NO 23 132** Size 10
- NO 23 133** Size 11
- NO 23 134** Size 12
- NO 23 135** Size 13
- NO 23 136** Size 14
- NO 23 137** Size 15
- NO 23 138** Size 16
- NO 23 139** Size 17
- NO 23 140** Size 18
- NO 23 141** Size 19
- NO 23 143** Size 21
- NO 23 144** Size 22
- NO 23 146** Size 24



With its 15° offset ring side, it is ideally suited for working on flat surfaces.

**7-piece MicroSpeeder set with reverse lever**

One each 8 – 10 – 13 – 16 – 17 – 18 and 19mm in a sturdy powder coated steel box.

**NO 23 124**



**MicroSpeeder ratcheting function. No swapping over of the spanner:**

**a real time saver. Extra long design.**

**Double ring MicroSpeeder in straight, slender design. Ideal for inserting into tight spaces.**



Straight design without reversing lever. The spanner is simply swapped over.

Often used for demounting engines, working on automatic transmissions, rear axles, etc. Ratcheting function with 72-teeth inner gear ring, made of high alloy special steel allowing ratcheting even when the spanner can only be moved through 5°. Shaft of CrV steel with optimum surface protection: double nickel-plating and single matt-finished chrome-plating. With durable laser marking and easy-to-read sizes.

|                  |              |                  |              |
|------------------|--------------|------------------|--------------|
| <b>NO 23 241</b> | Size 8 x 9   | <b>NO 23 247</b> | Size 14 x 15 |
| <b>NO 23 243</b> | Size 10 x 11 | <b>NO 23 249</b> | Size 16 x 18 |
| <b>NO 23 244</b> | Size 10 x 13 | <b>NO 23 250</b> | Size 17 x 19 |
| <b>NO 23 246</b> | Size 12 x 13 | <b>NO 23 252</b> | Size 22 x 24 |

**Hinged MicroSpeeder with self positioning ring head, tilting through 90° to both sides.**



The self positioning action of the hinged ring side substantially reduces work load, while its flexibility and durability remain unmatched. The self positioning action of the ring is ideal for tight locations.

**Hinged MicroSpeeder, individually**

|                  |           |
|------------------|-----------|
| <b>NO 23 045</b> | Size 8mm  |
| <b>NO 23 046</b> | Size 9mm  |
| <b>NO 23 047</b> | Size 10mm |
| <b>NO 23 048</b> | Size 11mm |
| <b>NO 23 049</b> | Size 12mm |
| <b>NO 23 050</b> | Size 13mm |
| <b>NO 23 051</b> | Size 14mm |
| <b>NO 23 052</b> | Size 15mm |
| <b>NO 23 053</b> | Size 16mm |
| <b>NO 23 054</b> | Size 17mm |
| <b>NO 23 055</b> | Size 18mm |
| <b>NO 23 056</b> | Size 19mm |
| <b>NO 23 058</b> | Size 21mm |
| <b>NO 23 059</b> | Size 22mm |
| <b>NO 23 061</b> | Size 24mm |

**7-piece Hinged MicroSpeeder set**

One each 8, 10, 13, 16, 17, 18 and 19mm of the long version, in a sturdy powder coated steel box.

**NO 23 068**

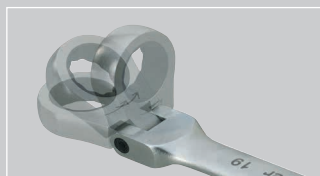

*Inversible joint:  
Unbeatable in tight places!*

# Quadruple MicroSpeeder. Just one tool for the four most important automotive

fasteners: 10 – 13 – 17 – 19mm.

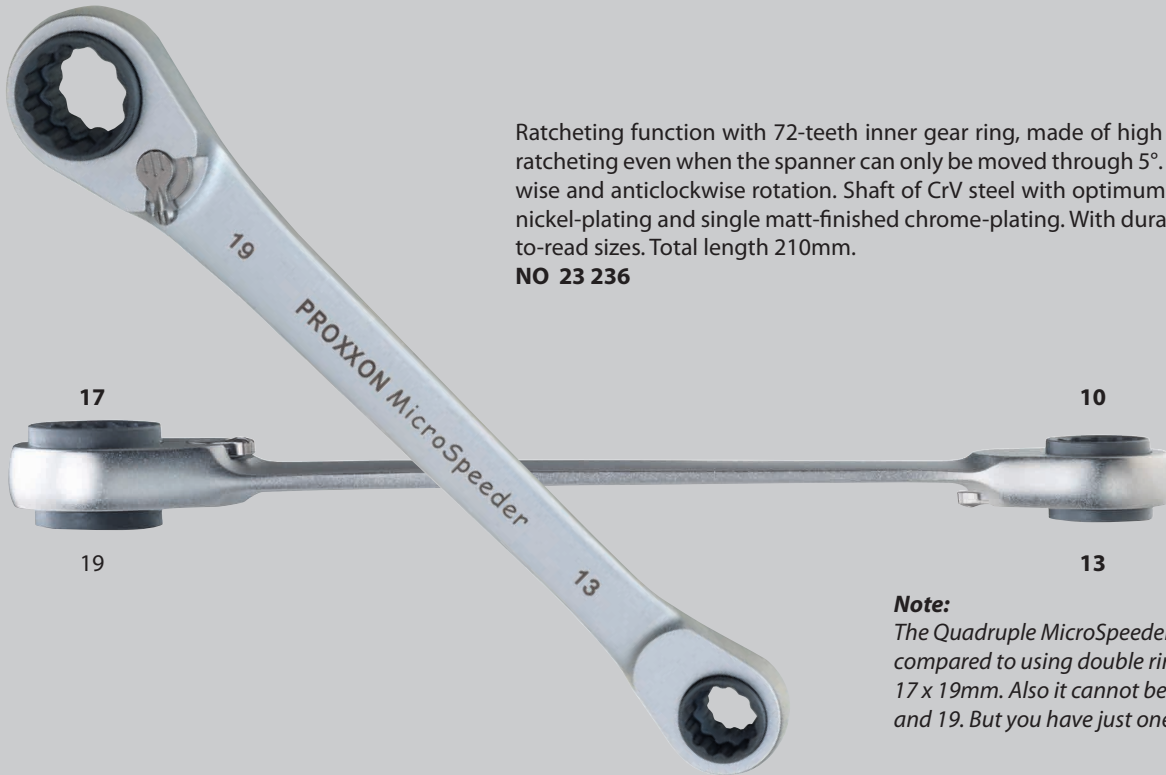

Ratcheting function with 72-teeth inner gear ring, made of high alloy special steel allowing ratcheting even when the spanner can only be moved through 5°. With reverse lever for clockwise and anticlockwise rotation. Shaft of CrV steel with optimum surface protection: double nickel-plating and single matt-finished chrome-plating. With durable laser marking and easy-to-read sizes. Total length 210mm.

**NO 23 236**

**Note:**

The Quadruple MicroSpeeder is somewhat bulkier when compared to using double ring MicroSpeeders 10 x 13 or 17 x 19mm. Also it cannot be passed through for sizes 13 and 19. But you have just one single tool in your pocket!

**Standard Speeder ratchet spanners. With reverse lever. Easy, handy and especially practical for installation work.**

### 6-piece Speeder ratchet spanner set

Spanners 6 – 19mm. One each in sizes 6 x 7, 8 x 9, 10 x 11, 12 x 13, 14 x 15 and 17 x 19mm. Reliable ratchet mechanism with inner ring gear of CrV steel (reversible). Packed in sturdy steel box (powder coated) with flap clasp. Tray with practical recess area for storage of small parts (the depicted nuts are not included in the scope of delivery).

**NO 23 231**

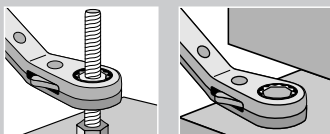

**DIN  
ISO**

### Speeder ratchet spanners, individually

|                  |         |                  |         |
|------------------|---------|------------------|---------|
| <b>NO 23 201</b> | 6 x 7   | <b>NO 23 211</b> | 14 x 15 |
| <b>NO 23 204</b> | 8 x 9   | <b>NO 23 214</b> | 16 x 18 |
| <b>NO 23 205</b> | 10 x 11 | <b>NO 23 215</b> | 17 x 19 |
| <b>NO 23 207</b> | 10 x 13 | <b>NO 23 216</b> | 19 x 21 |
| <b>NO 23 209</b> | 12 x 13 |                  |         |

# SlimLine spanners. Hands-on tools. CrV steel drop forged, carefully hardened and



- Optimal surface protection by means of double nickel-plating and single chrome-plating. With easy to hold, smooth finish.
- With durable laser inscribed and clearly readable sizes in mm.
- Polished heads: slim and thin walled. Torque characteristics still exceed DIN/ISO requirements.
- Dimensional tolerances are better than those required by DIN/ISO. Each piece is checked.

## 8-piece SlimLine open-end spanner set, including holder. To DIN 3110 and ISO 3318.

Includes 6 x 7, 8 x 9, 10 x 11, 12 x 13, 14 x 15, 16 x 17, 18 x 19 and 20 x 22mm. Supplied with a plastic holder with slot for each spanner and holes for attaching to a wall. All spanners clearly labelled to make them easy to find.

**NO 23 800** set

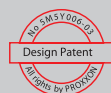

Each spanner has a clearly marked place for storage. The plastic holder also offers holes to allow for fixing it to a wall.

**PROXXON INDUSTRIAL SlimLine open-end spanners, individually**

| NO     | S <sub>1</sub> x S <sub>2</sub> | B <sub>1</sub> | B <sub>2</sub> | L   | H   |
|--------|---------------------------------|----------------|----------------|-----|-----|
| 23 828 | 5 x 5.5mm                       | 13             | 14             | 111 | 3   |
| 23 830 | 6 x 7 mm                        | 16             | 18             | 123 | 3.4 |
| 23 832 | 8 x 9 mm                        | 20             | 22             | 140 | 3.5 |
| 23 834 | 10 x 11 mm                      | 24             | 26             | 157 | 4.5 |
| 23 836 | 12 x 13 mm                      | 28             | 29             | 173 | 4.7 |
| 23 838 | 10 x 13 mm                      | 24             | 29             | 174 | 4.7 |
| 23 840 | 14 x 15 mm                      | 32             | 34             | 190 | 5.5 |
| 23 842 | 16 x 17 mm                      | 36             | 38             | 205 | 6   |
| 23 846 | 18 x 19 mm                      | 38             | 42             | 220 | 6.5 |
| 23 848 | 17 x 19 mm                      | 38             | 42             | 220 | 6.5 |
| 23 850 | 20 x 22 mm                      | 43             | 46             | 235 | 7.5 |
| 23 852 | 21 x 23 mm                      | 45             | 48             | 248 | 7.5 |
| 23 856 | 24 x 27 mm                      | 49             | 55             | 268 | 8.5 |
| 23 860 | 30 x 32 mm                      | 59             | 64             | 302 | 9.5 |
| 23 864 | 34 x 36 mm                      | 65             | 79             | 320 | 10  |
| 23 866 | 41 x 46 mm                      | 86             | 95             | 415 | 15  |



**12-piece SlimLine ring-combination spanner set. Including holder. To DIN 3113 and ISO 3318 (ring head offset 15°).**

Sizes 6 – 7 – 8 – 9 – 10 – 11 – 12 – 13 – 14 – 15 – 17 and 19mm. Each spanner has a clearly marked place for storage. The plastic holder also offers fixing holes.

**NO 23 820** set

**PROXXON INDUSTRIAL SlimLine combination spanners, individually**

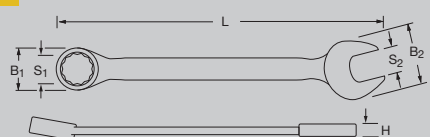

| NO     | S <sub>1</sub> | B <sub>1</sub> | B <sub>2</sub> | L   | H    |
|--------|----------------|----------------|----------------|-----|------|
| 23 905 | 5.5mm          | 9              | 14             | 93  | 3.3  |
| 23 906 | 6mm            | 10             | 16             | 100 | 3.5  |
| 23 907 | 7mm            | 12             | 18             | 110 | 3.5  |
| 23 908 | 8mm            | 13             | 20             | 120 | 4    |
| 23 909 | 9mm            | 15             | 22             | 130 | 4    |
| 23 910 | 10mm           | 16             | 24             | 140 | 4.5  |
| 23 911 | 11mm           | 17             | 26             | 150 | 4.9  |
| 23 912 | 12mm           | 19             | 28             | 160 | 5    |
| 23 913 | 13mm           | 20             | 29             | 170 | 5.5  |
| 23 914 | 14mm           | 22             | 32             | 180 | 5.8  |
| 23 915 | 15mm           | 24             | 34             | 190 | 5.9  |
| 23 916 | 16mm           | 25             | 36             | 195 | 5.9  |
| 23 917 | 17mm           | 25             | 38             | 210 | 6.4  |
| 23 918 | 1mm            | 28             | 38             | 216 | 6.9  |
| 23 919 | 19mm           | 28             | 42             | 230 | 7.1  |
| 23 920 | 20mm           | 30             | 46             | 250 | 7.3  |
| 23 921 | 21mm           | 32             | 45             | 245 | 7.5  |
| 23 922 | 22mm           | 33             | 46             | 270 | 8.2  |
| 23 924 | 24mm           | 36             | 49             | 280 | 8.3  |
| 23 927 | 27mm           | 39             | 55             | 310 | 9.1  |
| 23 930 | 30mm           | 44             | 59             | 340 | 10   |
| 23 932 | 32mm           | 46             | 64             | 360 | 10.8 |
| 23 933 | 34mm           | 50             | 70             | 380 | 15   |
| 23 935 | 36mm           | 54             | 74             | 410 | 18   |
| 23 937 | 41mm           | 61             | 84             | 460 | 21   |

**15-piece SlimLine combination spanner set. With the new ISO sizes 16, 18 and 21mm. Otherwise as described on the left.**

Sizes 6 – 7 – 8 – 9 – 10 – 11 – 12 – 13 – 14 – 15 – 16 – 17 – 18 – 19 and 21mm.

**NO 23 821** set

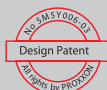

*SlimLine-double ring and SlimLine combination spanner sets in canvas roll bag (for metric and imperial screw sizes) are featured on pages 30/31.*



**SlimLine spanners. Forged from CrV steel, carefully hardened and plated.**

**With clearly readable sizes.**



Each spanner has a clearly marked place for storage. The plastic holder also offers holes to allow for fixing it to a wall.

**8-piece SlimLine double ring spanner set. Including holder. To DIN 838 and ISO 3318.**

Sizes 6 x 7, 8 x 9, 10 x 11, 12 x 13, 14 x 15, 16 x 17, 18 x 19 and 20 x 22mm.

Each spanner has a clearly marked place for storage. The plastic holder also offers holes to allow for fixing it to a wall.

**NO 23 810** set



**PROXXON INDUSTRIAL SlimLine double ring spanners, individually**

| NO     | S <sub>1</sub> x S <sub>2</sub> | B <sub>1</sub> | B <sub>2</sub> | L   | H    |
|--------|---------------------------------|----------------|----------------|-----|------|
| 23 868 | 5 x 5,5 mm                      | 9              | 10             | 162 | 5    |
| 23 870 | 6 x 7 mm                        | 10             | 12             | 173 | 5.6  |
| 23 872 | 8 x 9 mm                        | 13             | 14             | 182 | 6.1  |
| 23 874 | 10 x 11 mm                      | 16             | 17             | 200 | 7.9  |
| 23 876 | 12 x 13 mm                      | 18             | 19             | 212 | 8.5  |
| 23 878 | 10 x 13 mm                      | 16             | 19             | 212 | 8.5  |
| 23 880 | 14 x 15 mm                      | 21             | 23             | 225 | 9.8  |
| 23 882 | 16 x 17 mm                      | 24             | 25             | 245 | 10.4 |
| 23 886 | 18 x 19 mm                      | 27             | 28             | 260 | 11.3 |
| 23 888 | 17 x 19 mm                      | 25             | 28             | 216 | 11.3 |
| 23 890 | 20 x 22 mm                      | 30             | 32             | 285 | 12.8 |
| 23 892 | 21 x 23 mm                      | 31             | 33             | 310 | 12.9 |
| 23 896 | 24 x 27 mm                      | 34             | 38             | 335 | 13.9 |
| 23 900 | 30 x 32 mm                      | 42             | 45             | 375 | 15.3 |



**SlimLine spanners, packed in cardboard box.**

**Complete sets for sizes from 6 to 32mm. Hands-on tools.**

**21-piece SlimLine combination spanner set. From 6 to 32mm. To DIN 3113 and ISO 3318 (15° offset ring head).**



Sizes 6 – 7 – 8 – 9 – 10 – 11 – 12 – 13 – 14 – 15 – 16 – 17 – 18 – 19 – 20 – 21 – 22 – 24 – 27 – 30 and 32mm. Clearly arranged in a sturdy cardboard box.

**NO 23 822** set

**11-piece SlimLine open-end spanner set. From 6 to 32mm. To DIN 3110 and ISO 3318.**



Sizes 6 x 7, 8 x 9, 10 x 11, 12 x 13, 14 x 15, 16 x 17, 18 x 19, 20 x 22, 21 x 23, 24 x 27 and 30 x 32mm. Clearly arranged in a sturdy cardboard box.

**NO 23 802** set

**11-piece SlimLine double ring spanner set. From 6 to 32mm. To DIN 838 and ISO 3318.**



Sizes 6 x 7, 8 x 9, 10 x 11, 12 x 13, 14 x 15, 16 x 17, 18 x 19, 20 x 22, 21 x 23, 24 x 27 and 30 x 32mm. Clearly arranged in a sturdy cardboard box.

**NO 23 812** set

**SlimLine combination spanner sets for metric and imperial screw sizes. With 15° offset ring head. In practical canvas roll bag with holes for hanging up.**

**12-piece SlimLine combination spanner set for metric screw sizes.**



Spanner sizes: 6 – 7 – 8 – 9 – 10 – 11 – 12 – 13 – 14 – 15 – 17 and 19mm.

**NO 23 825**

**12-piece SlimLine combination spanner set for imperial screw sizes.**



Spanner sizes: 1/4" – 9/32" – 5/16" – 11/32" – 3/8" – 7/16" – 1/2" – 9/16" – 5/8" – 11/16" – 3/4" and 13/16".

**NO 23 816**



**Note:**

Practical bag for hanging up in the workshop or to roll up for on the way.



## Super safety and speciality bit set.

**Nothing is impossible to unscrew!**

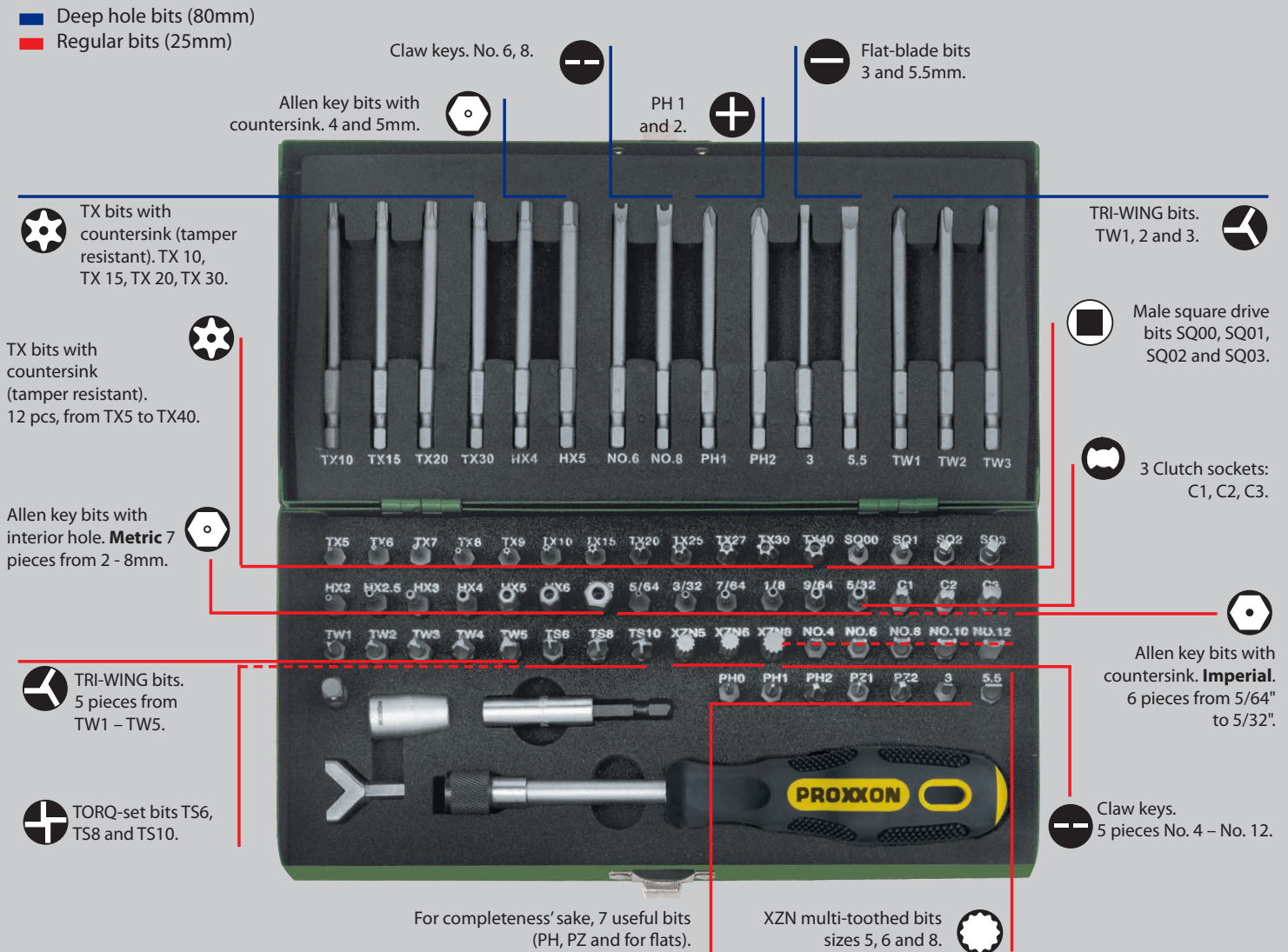

## 75-piece super safety and speciality bit set

With 1/4" special bits (6.3mm) in standard length (25mm) and extra long for tapped blind holes (80mm). Including screwdriver with positive spring-sleeve holder for bits. Magnetic holder for work with electric screwdriver or drill. Adapter with male square and male hex drive and matching attachment with female square and female hex drive.

Special attachment for centrally clamping screw hooks and similar parts. All in sturdy steel box with powder coated finish. All parts are clearly marked.

**NO 23 107**

## Precision mechanics set with 1/4" MICRO bit ratchet, 36 parts

**For screwing where space is tight. No bit adapter required!**  
MICRO bit ratchet with 1/4" hexagon holding fixture. With magnetic insert. Distance from change-over lever to tip of bit only 30mm. With extremely slender head (23 x 12mm). Fine toothed: several of the 72 teeth engage at the same time and transfer a high torque. Change-

over lever for clockwise - anticlockwise rotation. Forged of CrV steel, 2 x nickel and matt-finished chrome plating. Handle of oil and acid-resistant TPR (thermoplastic rubber). Total length 120mm.

**NO 23 109**



## Screwdriver set with foldable ratchet-screwdriver and magnetic holder for working with electric screwdrivers.

PROXXON

INDUSTRIAL

|   | 25mm                            | 80mm                    |
|---|---------------------------------|-------------------------|
| ⊖ | FD 3-5.5-7                      | 3-5.5-10                |
| + | PH 1-2-3                        | 1-2                     |
| ✳ | PZ 1-2-3                        |                         |
| ✳ | TTX 8-9-10-15-20<br>25-27-30-40 |                         |
| ✳ | TX                              | 10-15-20-25<br>27-30-40 |
| ⊕ | HX 2.5-3-4-5-6                  | 3-4-5-6                 |



### Screwdriver set with foldable ratchet-screwdriver and magnetic holder, 54-piece.

With 35 bits 1/4" (6.3mm) in standard length (25mm) and 16 bits extra long (80mm) for tapped blind holes. Including adapter with male square and male hex drive as well as matching attachment with female square and female hex drive. Special attachment for centrally clamping screw hooks and similar parts. 10 sockets 1/4" from 5.5 – 13mm. In addition, magnetic holder for work with electric screwdriver or drill. In sturdy steel box (powder-coated).

NO 23 104

### Foldable screwdriver with ratchet mechanism: To reach higher torque, simply bend the screwdriver handle. No need to swap over. For 1/4" standard bits.



Locking of the handle in normal and angled position at the push of a button. Reverse lever for clockwise and anticlockwise rotation by turning the shift ring. In centre position the ratchet function is eliminated. Autolock system: Bits are form-locked automatically when inserted by means of a spring and a magnet. To release, slide ejector backwards.

NO 22 288

### Bits in industrial quality, accurate and wear resistant.



Made of special chrome-molybdenum-silicon-manganese-vanadium steel alloy. Hardened according to latest production standards.

|   | 25mm                            | 80mm           |
|---|---------------------------------|----------------|
| ✳ | TTX 8-9-10-15-20<br>25-27-30-40 | 10-15-20-25-30 |
| ⊕ | HX 2-2.5-3-4-5-6-8              | 3-4-5          |
| ✳ | XZN 5-6-8                       |                |
| + | PH 0-1-2                        | 1              |
| ✳ | PZ 1-2                          |                |
| ⊖ | FD 3.5                          |                |



# FLEX-DOT screwdrivers. The allrounders for workshop and assembly.

PROXXON

INDUSTRIAL

DIN  
ISO

## Ergonomic design for proper handling:

Rounded two-component handle with flexible "FLEX-DOT®" nubs for fatigue-proof and comfortable continuous use. Excellent grip attitude also with quick regripping. Combines high torques and pressure forces with balanced design for horizontal and vertical approach.

With transverse hole for hanging up or applying a lever.

Oil- and acid resistant non-stick special rubber handle.

Easy-to-read sizes through laser marking process on matte-chrome plated shafts of chrome-silicon-manganese-molybdenum special alloy steel.

Processed black tip for greatest precision for accepting screws. Also prevents tool from slipping.

Blade symbol and size on end of grip.

Finger recesses for more grip during fast turning.

With hexagon flat for using an open-end spanner as lever (for sizes 8 and 10 on slotted and PH3 and PZ3 version).



## Flat-blade screwdrivers

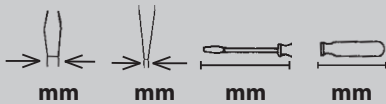

| NO               | mm  | mm  | mm  | mm  |
|------------------|-----|-----|-----|-----|
| 22 010           | 3   | 0,5 | 100 | 75  |
| 22 012           | 4   | 0,8 | 100 | 75  |
| 22 014           | 5.5 | 1   | 125 | 100 |
| 22 016           | 6.5 | 1,2 | 150 | 110 |
| 22 018           | 8   | 1,2 | 175 | 122 |
| 22 020           | 10  | 1,6 | 200 | 122 |
| 22 026<br>Stubby | 5.5 | 1   | 25  | 60  |

## HX (ball head) screwdrivers

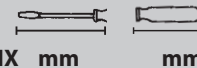

| NO     | Internal HX | mm  | mm  |
|--------|-------------|-----|-----|
| 22 204 | 2           | 100 | 75  |
| 22 206 | 2.5         | 100 | 75  |
| 22 208 | 3           | 100 | 75  |
| 22 210 | 4           | 100 | 100 |
| 22 212 | 5           | 100 | 110 |
| 22 214 | 6           | 150 | 110 |
| 22 216 | 8           | 150 | 122 |



## PHILLIPS screwdrivers

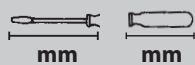

| NO               | PH | mm  | mm  |
|------------------|----|-----|-----|
| 22 050           | 0  | 60  | 75  |
| 22 052           | 1  | 80  | 100 |
| 22 054           | 2  | 100 | 110 |
| 22 056           | 3  | 150 | 122 |
| 22 060<br>Stubby | 2  | 25  | 60  |



## POZIDRIV Phillips screwdrivers





| NO     | PZ | mm  | mm  |
|--------|----|-----|-----|
| 22 070 | 0  | 60  | 75  |
| 22 072 | 1  | 80  | 100 |
| 22 074 | 2  | 100 | 110 |
| 22 076 | 3  | 150 | 122 |



### TX Tamper screwdrivers (with frontal hole)

| NO     | TTX |  |  |
|--------|-----|---|---|
|        |     | mm  | mm  |
| 22 230 | 8   | 75  | 75  |
| 22 232 | 10  | 100   | 100   |
| 22 234 | 15  | 100   | 100   |
| 22 236 | 20  | 100   | 100   |
| 22 238 | 25  | 100   | 110   |
| 22 240 | 27  | 100   | 110   |
| 22 242 | 30  | 100   | 110   |
| 22 244 | 40  | 100   | 110   |

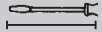
### X nut screwdrivers

| NO     | Exterior HX |  |  |
|--------|-------------|---|---|
|        |             | mm  | mm  |
| 22 260 | 5.5         | 125   | 110   |
| 22 262 | 6           | 125   | 110   |
| 22 264 | 7           | 125   | 110   |
| 22 266 | 8           | 125   | 110   |
| 22 268 | 9           | 125   | 110   |
| 22 270 | 10          | 125   | 110   |
| 22 272 | 11          | 125   | 110   |
| 22 274 | 12          | 125   | 110   |
| 22 276 | 13          | 125   | 110   |

## Popular screwdriver combinations for daily use.

Combinations that are a must-have for every tool box.  
Complete initial equipment for mechanics and service technicians.

### FLEX-DOT 6-piece screwdriver sets

| NO     |   |                        |        |    |     |     |
|--------|---|------------------------|--------|----|-----|-----|
| 22 604 |  | <b>Flat-blade:</b>     | 3      | 4  | 5.5 | 6.5 |
|        |  | <b>2 x Phillips:</b>   | PH 1   | 2  |     |     |
| 22 606 |  | <b>4 x Flat-blade:</b> | 3      | 4  | 5.5 | 6.5 |
|        |  | <b>2 x Pozidriv:</b>   | PZ 1   | 2  |     |     |
| 22 640 |  | <b>6 x Tamper-TX:</b>  | TTX 10 | 15 | 20  |     |
|        |   |                        | 25     | 30 | 40  |     |
| 22 642 |  | <b>6 x HX:</b>         | HX 2.5 | 3  | 4   |     |
|        |   |                        | 5      | 6  | 8   |     |
| 22 644 |  | <b>6 x HX:</b>         | 5.5    | 6  | 7   |     |
|        |   | <b>External</b>        |        | 8  | 10  | 13  |



## Screwdrivers for 1/4" standard bits and 1/4" sockets

For 1/4" hexagon standard bits (6.3mm). Steel screws stick to magnetised bit which facilitates positioning of the screws.

NO 22 281



mm  
100



mm  
110

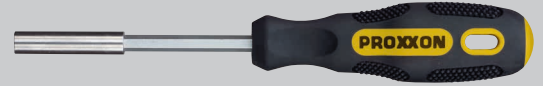

For standard 1/4" hex bits (6.3mm). The auto-lock-system positively holds the bit. To release, push the sleeve backwards.

NO 22 282



mm  
110

mm  
110



For use with 1/4"-square sockets or 1/4"-hexagon standard bits (6.3mm). Choice between the two options simply by sliding the sleeve.

NO 22 283



mm  
110

mm  
110

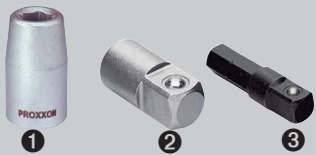
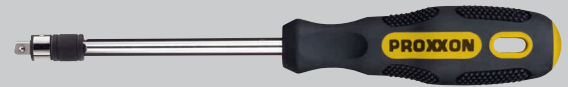

- ❶ **1/4" adapter for hexagonal bits**  
(DIN 3126) female square to female hexagon
- ❷ **1/4"-adapter**  
1/4" female square to 3/8" male square
- ❸ **1/4"-adapter**  
with 1/4" male square to 1/4" male hexagon

NO

23 780

23 782

23 701

### MICRO special hook set, 4-piece

For the automotive sector, industry and trade. Ideal for disconnecting wires, removing small fuses or (dis-)assembly of O-rings. Including 4 types of hooks: (1) straight tip, (2) 90° angled tip, (3) 45° angled tip, (4) full hook tip. Blade Ø 3mm. Blade length 80mm. Overall length 155mm.

NO 22 700

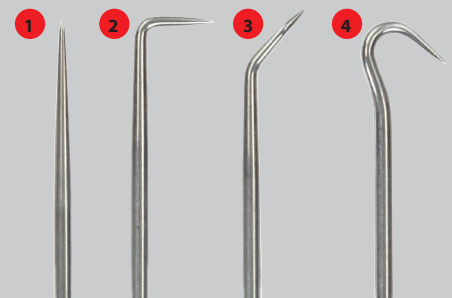

Packaged in a practical zipper case. Including one tweezer for gripping small screws and small parts.

### Precision screwdrivers for electronic engineers, camera builders, watch

#### MICRO-Driver, 13-piece

|   |                    |   |
|---|--------------------|---|
| ⊖ | <b>Flat-blade:</b> | 1 x 50 – 2 x 50                             |
| ⊕ | <b>Phillips:</b>   | PH 000 x 50 – PH 0 x 50 – PH 1 x 50         |
| ⊛ | <b>TX:</b>         | 5 x 50 – 6 x 50 – 7 x 50 – 8 x 50 – 10 x 50 |
| ⊠ | <b>HX:</b>         | 1.5 x 50 – 2 x 50                           |

NO 22 720

# Insulated FLEX-DOT screwdrivers to VDE-Standard

Insulated VDE screwdrivers for work on or around live components up to 1,000V AC. Injection of the protective insulation onto the screwdriver blade and piece by piece inspection offer maximum safety. SLIM-type blade as of size Flat-blade 4.



Standard-blade

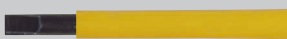

SLIM-type-blade



| — Insulated flat-blade screwdrivers |     |     |     |     |
|-------------------------------------|-----|-----|-----|-----|
| NO                                  | mm  | mm  | mm  | mm  |
| 22 300                              | 2.5 | 0.4 | 75  | 75  |
| 22 304                              | 4   | 0.8 | 100 | 100 |
| 22 306                              | 5.5 | 1   | 125 | 100 |
| 22 308                              | 6.5 | 1.2 | 150 | 110 |

| + Insulated PHILLIPS screwdrivers |    |     |     |
|-----------------------------------|----|-----|-----|
| NO                                | PH | mm  | mm  |
| 22 330                            | 0  | 60  | 75  |
| 22 332                            | 1  | 80  | 100 |
| 22 334                            | 2  | 100 | 110 |

## Insulated combination blade SL/PZ screwdrivers



The new blade type exactly fits combination screws (slotted/pozidriv) frequently used in electrical installation, e.g. in switch cabinets, fuse boxes and terminal blocks.

| NO     |       |           |
|--------|-------|-----------|
| 22 342 | SL/PZ | 1 x 80mm  |
| 22 344 | SL/PZ | 2 x 100mm |

## 6-piece insulated VDE screwdriver set

| NO     |                |     |      |      |     |
|--------|----------------|-----|------|------|-----|
| 22 630 | 4 x Flat-blade | 2.5 | 4    | 5.5  | 6.5 |
|        | 2 x PH         |     | PH 1 | PH 2 |     |



## Voltage tester as per VDE 0680

Indication of voltage between phases 220 to 250V, 50/60Hz (up to 500Hz). Of high-strength ABS, with roughened, non-slip surface. Tested piece by piece at 2,000V. Blade length 60mm. Total length 140mm.

| NO     | mm  | mm  | mm | mm  |
|--------|-----|-----|----|-----|
| 22 390 | 3   | 0.5 | 60 | 75  |
| 22 392 | 3.5 | 0.5 | 80 | 100 |

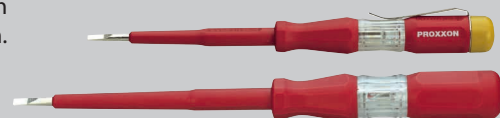

## makers, jewellers, precision engineers and model makers.

## 15-piece MICRO-Driver set

Blades of high alloy nickel-chrome-molybdenum steel for maximum hardness and toughness. Chrome-plated with brinelled tip. With ergonomically formed two-component handle of high-quality plastic (impact as well as oil and acid resistant) with soft component in the finger grip area. The revolving top and finger mould improve easy of use.

|               |  |
|---------------|--|
| — Flat-blade: | 1 x 50 – 2 x 50 – 3 x 50                     |
| + Phillips:   | PH 000 x 50 – PH 0 x 50 – PH 1 x 50          |
| ⊕ TX:         | 5 x 50 – 6 x 50 – 8 x 50 – 10 x 50 – 15 x 50 |
| ⊙ HX:         | 1.5 x 50 – 2 x 50 – 2.5 x 50 – 3 x 50        |

NO 28 148



## L-handle screwdrivers: Very robust with continuous blade.

**PROXXON**  
**INDUSTRIAL**

If high torques are required for tightening or loosening screws, the L-handle screwdriver is the solution. The ergonomic and asymmetrical grip simplifies handling under continuous operation. Its two-component design with soft zones reduces pressure marks while at the same time allowing for optimum torque transfer. Easy-to-read sizes on shaft (laser marking) and handle.

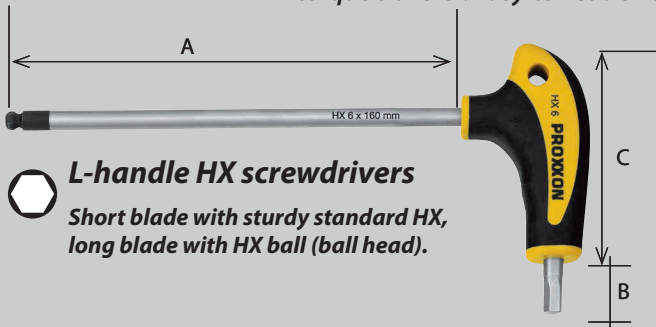

### L-handle HX screwdrivers

Short blade with sturdy standard HX, long blade with HX ball (ball head).

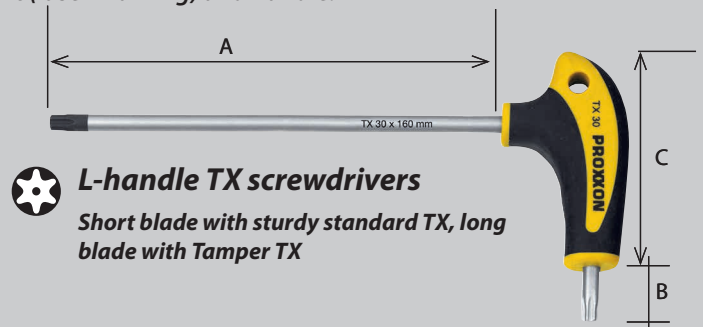

### L-handle TX screwdrivers

Short blade with sturdy standard TX, long blade with Tamper TX

| NO     | HX  | A mm | B mm | C mm |
|--------|-----|------|------|------|
| 22 402 | 2   | 110  | 15   | 55   |
| 22 404 | 2,5 | 110  | 15   | 55   |
| 22 406 | 3   | 110  | 15   | 55   |
| 22 408 | 4   | 110  | 15   | 55   |
| 22 410 | 5   | 160  | 20   | 75   |
| 22 412 | 6   | 160  | 20   | 75   |
| 22 414 | 7   | 160  | 20   | 75   |
| 22 416 | 8   | 200  | 20   | 75   |
| 22 418 | 10  | 215  | 20   | 100  |

| NO     | TX | A mm | B mm | C mm |
|--------|----|------|------|------|
| 22 440 | 8  | 110  | 15   | 55   |
| 22 442 | 9  | 110  | 15   | 55   |
| 22 444 | 10 | 110  | 15   | 55   |
| 22 446 | 15 | 110  | 15   | 55   |
| 22 448 | 20 | 110  | 15   | 55   |
| 22 450 | 25 | 160  | 20   | 75   |
| 22 452 | 27 | 160  | 20   | 75   |
| 22 454 | 30 | 160  | 20   | 75   |
| 22 456 | 40 | 185  | 20   | 75   |
| 22 458 | 45 | 215  | 20   | 100  |
| 22 460 | 50 | 215  | 20   | 100  |



### L-handle screwdriver sets

With versatile holder for the workshop. Clearly specified sizes on the holder for neat storage of L-handle screwdrivers.

| NO     | Contents  |
|--------|---|
| 22 650 | 8-piece L-handle HX set with holder<br>HX 2 - 2.5 - 3 - 4 - 5 - 6 - 8 - 10                |
| 22 652 | 10-piece L-handle TX set with holder<br>TX 8 - 10 - 15 - 20 - 25 - 27 - 30 - 40 - 45 - 50 |



### 9-piece Allen key set

With spherical finish on the long end (short end chamfered).  
One each 1.5 - 2 - 2.5 - 3 - 4 - 5 - 6 - 8 and 10mm.  
Chrome-vanadium steel. In foldable plastic holder.  
**NO 23 946**

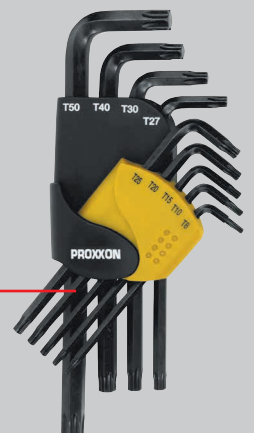

### 9-piece TX set

One each TX 8 - 10 - 15 - 20 - 25 - 27 - 30 - 40 and 50.  
Made from Nickel-Chrome-Molybdenum special steel.  
In foldable plastic holder.  
**NO 23 944**

**Perfect for effortless oil changes in 2 – 3 minutes.**

**Universal and oil siphoning pump AP 12**

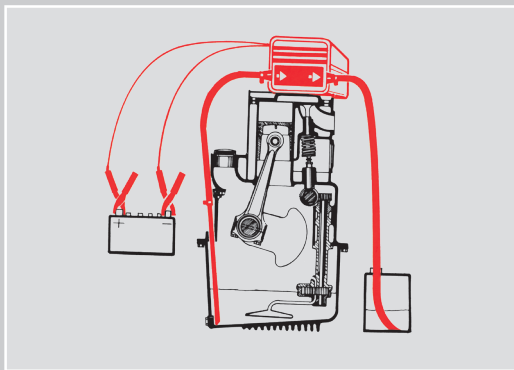

**Note:**  
The wand fits all vehicles with a 6mm oil dipstick shaft.

**Easily pumps motor, diesel and heating oil.**

Pump capacity approx. 250l/hr (with 1/2" feed hose). When changing oil with the wand, approx. 3l/min (40 °C oil temperature). 200cm long feed line with crocodile clips for battery terminals. Feed and supply side connect-ing pieces for 1/2" hoses. Includes a wand (approx. 800mm long, outer diameter 6mm) for the oil dipstick

shaft, permanently fitted with a reinforced hose. A 1/2" transparent outlet hose, approx. 150cm long, is supplied. Housing of glass fibre reinforced POLYAMIDE, approx. 120 x 90 x 90mm. Approx. weight 1.4kg.

**NO 25 262**

**8-piece pocket Allen key set**

One each 1.5 – 2 – 2.5 – 3 – 4 – 5 – 6 and 8mm. Made from Chrome-Molybdenum special steel, galvanically plated. In pocket knife type plastic holder which also serves as a handle.

**NO 23 956**



**8-piece pocket TX key set**

One each TX 9 – 10 – 15 – 20 – 25 – 27 – 30 and 40. Made from Nickel-Chrome-Molybdenum special steel. In pocket knife type plastic holder which also serves as a handle.

**NO 23 954**



# Contents

|   | Page/Pages  |
|---|---|
|    | <b>Socket sets and tool sets</b><br><b>14-piece 3/4" socket set</b><br>2 – 10<br>18             |
|    | <b>Ratchets, socket sets and drive elements</b><br>11 – 18                                      |
|    | <b>Special workshop sets, adjustable wrenches</b><br><b>IMPACT sockets for wheel nuts</b><br>19 |
|    | <b>MicroClick torque screwdrivers and</b><br><b>MicroClick torque wrenches</b><br>20 – 23<br>22 |
|   | <b>MicroSpeeder and speeder ratchet spanners</b><br>24 – 27                                     |
|  | <b>SlimLine spanners</b><br>28 – 31   |
|  | <b>Specialty bit sets</b><br>32 – 33  |
|  | <b>FLEX-DOT screwdrivers</b><br><b>MICRO-Driver</b><br>34 – 38<br>36 – 37                       |
|  | <b>Key and pocket key sets</b><br><b>Universal and oil suction pump AP 12</b><br>38 – 39<br>39  |

For the PROXXON MICROMOT-system there is a separate 76-page catalogue, which is available free of charge. Please send your request to the below mentioned address.



We reserve the right for technical modifications as a result of improvements.

## PROXXON GmbH

Industriepark Region Trier • Dieselstraße 3 - 7 • DE-54343 Föhren  
Phone: + 49 (0) 65 02 - 93 17 - 0 • Fax: + 49 (0) 65 02 - 93 17 - 200  
e-mail: [export@proxxon.com](mailto:export@proxxon.com) • [www.proxxon.com](http://www.proxxon.com)